



**Twin Falls Archway Project
Ad Hoc Citizens Advisory Committee
Agenda**

Thursday, October 4, 2018, 8:45 AM

Members: Jeanette Roe, John Kapeleris, Leonard Anderson, Paula Brown Sinclair, Rex Lytle, Tony Prater, Ruth Pierce, Melissa Crane

Facilitator: Kathy Markus

Advisors: Greg Middlekauff, Micah Campbell, and Nikki Boyd

Staff: Mitch Humble, Lisa Strickland

- 1) Confirmation of Quorum/Call Meeting to Order
- 2) Consent Calendar
 - a) Approval of Minutes
Purpose: **ACTION ITEM**
- 3) General Discussion
 - a) Engineering Modification
Purpose: **Discussion** By: Kathy Markus
 - b) Location of Archway
Purpose: **ACTION ITEM** By: Kathy Markus
- 4) Upcoming Meeting(s)
- 5) Adjournment

Any person(s) needing special accommodations to participate in the above-noticed meeting could contact Kathy Markus (208) 735-7222 at least two working days before the meeting. Si desea esta información en español, llame Leila Sanchez (208) 735-7287.



Date: Thursday, October 4, 2018
To: Honorable Mayor and City Council
From:

ACTION ITEM

Request:

Approval of Minutes

Time Estimate:

Background:

Approval Process:

Budget Impact:

Regulatory Impact:

History:

N/A

Analysis:

N/A

Conclusion:

Attachments:

1. 08-02-18 Archway Minutes



Twin Falls Archway Project Ad Hoc Citizens Advisory Committee Minutes

Thursday, August 2, 2018, 8:45 AM

203 Main Ave E
Twin Falls, ID 83301

Special Meeting

Members: Jeanette Roe, John Kapeleris, Leonard Anderson, Paula Brown Sinclair, Rex Lytle, Tony Prater, Ruth Pierce, Melissa Crane

Facilitator: Kathy Markus

Advisors: Greg Middlekauff, Micah Campbell, and Nikki Boyd

Staff: Mitch Humble, Lisa Strickland

1) Confirmation of Quorum/Call Meeting to Order

IT Director Markus called the meeting to order.

2) Consent Calendar

a) Approval of minutes from the following meeting: 06-28-18

3) Items for Discussion

a) Sign up for Beer Fest

All of the information for the Beer Fest has been packed for Melissa and is ready for Saturday. The vendor entrance will be located in the Park next to the bathroom. Melissa will be set up at 11:00 a.m. The booths are more centralized so it should not be as spread out at the Western Days Event.

b) Engineering Modification

IT Director Markus explained they have received the amendment to the foundation with an estimate so that the rose garden does not have to be removed and to avoid damaging a tree. There has not been support for moving the Archway in front of the Courthouse and there is support for the location being proposed but it still needs to go through the County Commissioners. Deputy City Manager Humble, Member Pierce and Member Middlekauff will be doing the presentation for the County

c) Fundraising

IT Director Markus updated the committee on the fundraising. She had very positive contacts made during the Art In The Park Event. Member Prater explained that he has had some citizens explain that they are not in support of this because they felt the money could be raised for more important things. Member Lytle explained that she likes the Chamber of Commerce but they are not in support of this project. Member Cane suggested contacting Carolyn White about the Thousand Springs Festival and having a booth. Member Prater will be contacting Rise and Shine again to get an appointment.

4) General Input/Announcements - Public/Staff

5) Upcoming Meeting(s)

September 6, 2018 at 8:45 a.m.

6) Adjournment

Lisa A. Strickland, Administrative Assistant

TWIN FALLS
ARCHWAY
TWIN FALLS, ID

CLIENT:
LYTLE SIGNS INC.

PROJECT NUMBER:
15975

DATE: 04-04-2018

SCALE: NO SCALE

DRAWN BY: JS

DESIGNED BY: JS

REVISIONS:
NO. DATE

1 4-17-18 - REVISED
FRAME SPAN TO END IN COLUMN
BRACING, NOT COLUMN VERTICALS

2 7-24-18 - REVISED
FOOTING SIZE

3

4

5



7-24-2018

SHEET:
2 of 25

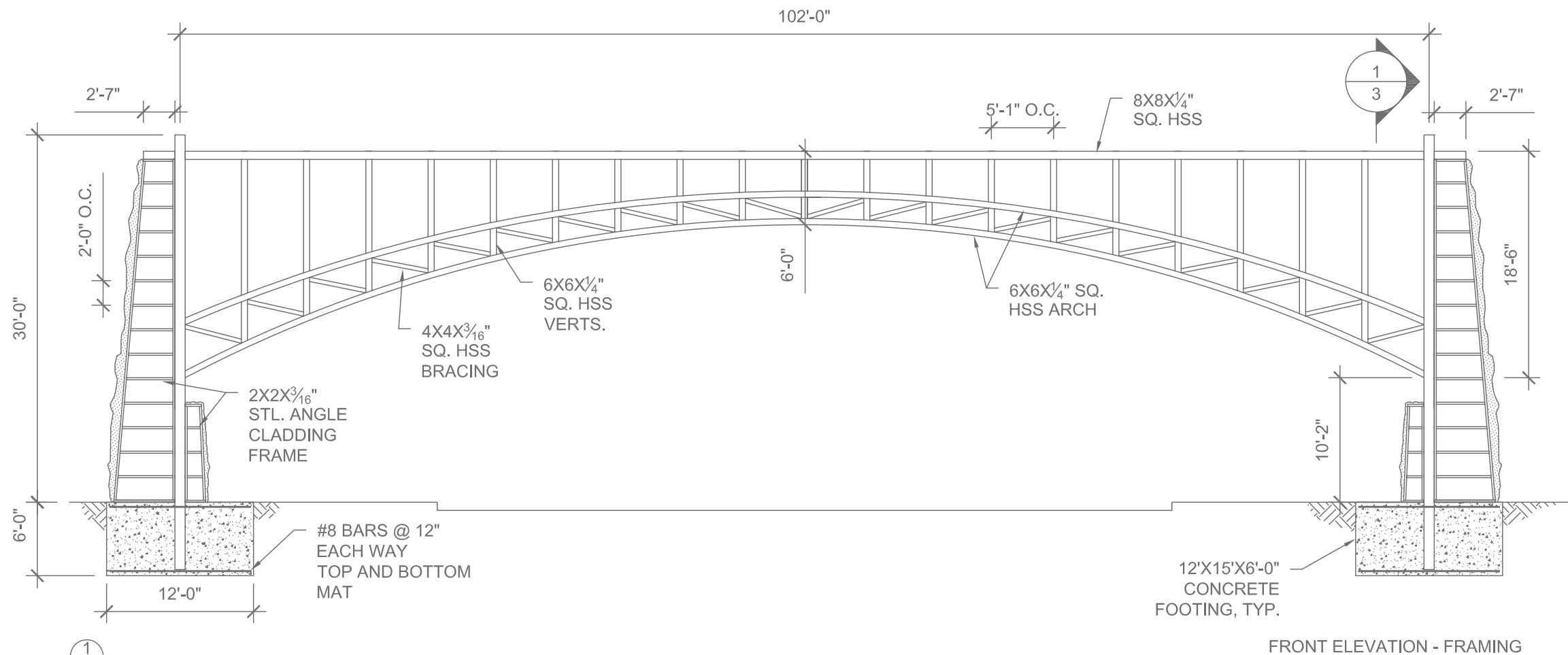

FRONT ELEVATION - FRAMING

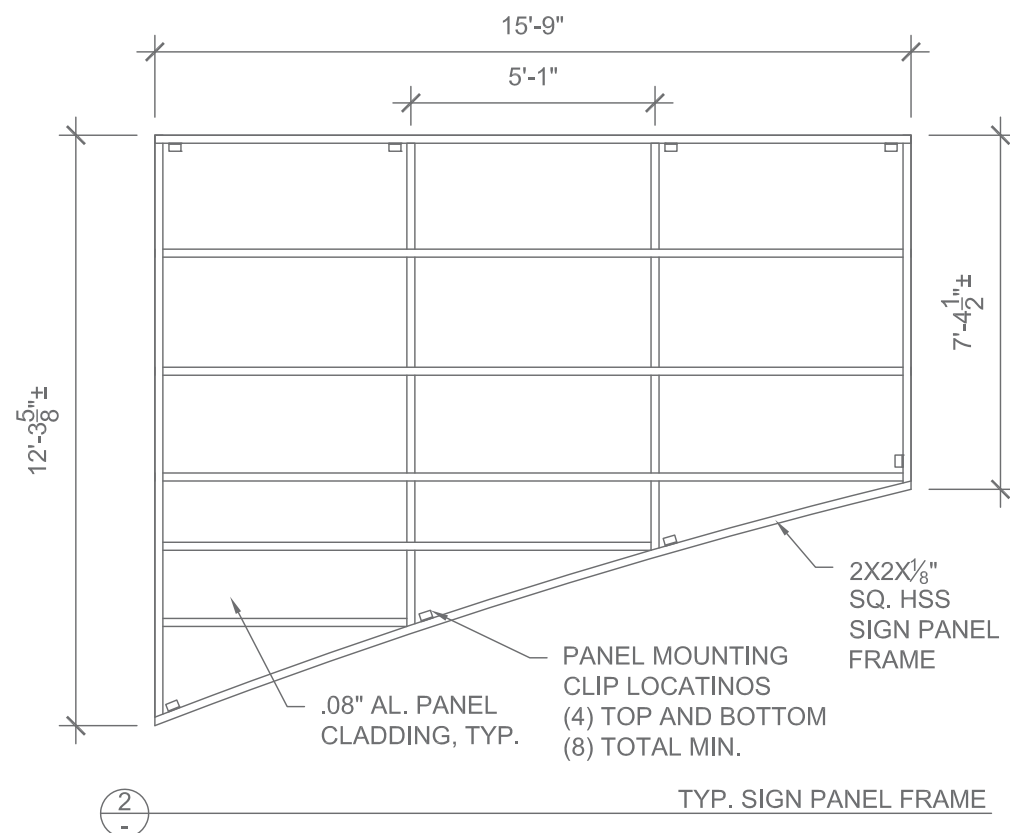

TYP. SIGN PANEL FRAME

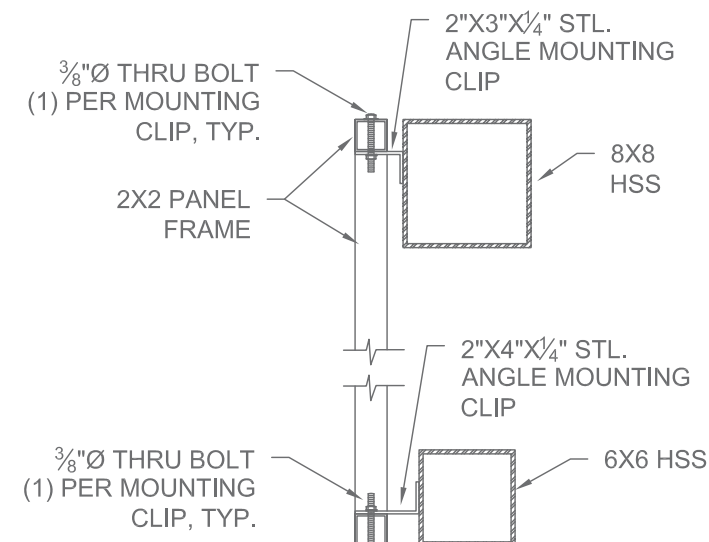

TYP. PANEL FRAME TO ARCH CONNECTION

TWIN FALLS
ARCHWAY
TWIN FALLS, ID

CLIENT:
LYTLE SIGNS INC.

PROJECT NUMBER:
15975

DATE: 04-04-2018

SCALE: NO SCALE

DRAWN BY: JS

DESIGNED BY: JS

REVISIONS:
NO. DATE

1	4-17-18 - REVISED FRAME SPAN TO END IN COLUMN BRACING, NOT COLUMN VERTICALS
2	7-24-18 - REVISED FOOTING SIZE
3	
4	
5	



7-24-2018

SHEET:
3 of 25

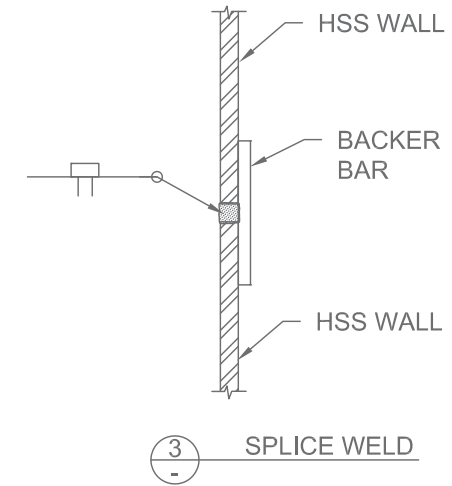
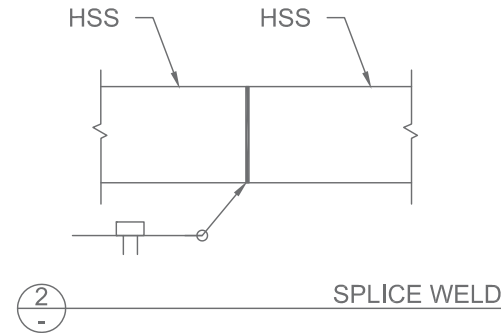
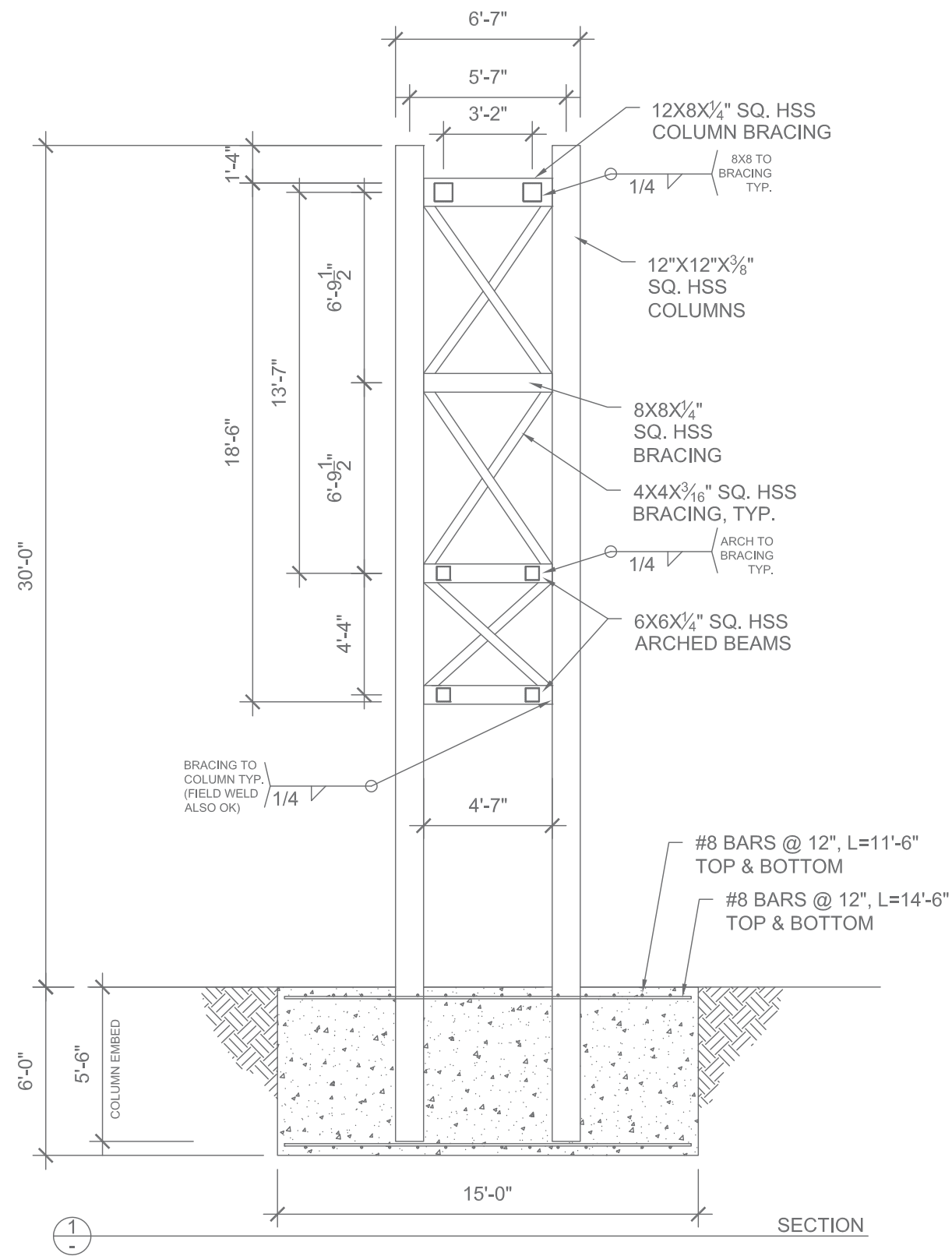

PROJECT: Twin Falls - Archway
PROJ. NO.: 15975
CLIENT: Lytle Signs, Inc.

DATE: 3/9/2018
ENGINEER: JS

Applied Wind Loads Per AASHTO LRFD Specifications for Structural Supports for Highway signs

$P_z = 0.00256 \cdot K_z \cdot K_d \cdot G \cdot V^2 \cdot C_d$ eq. 3.8.1-1
 $K_z = 1.0$ (Sec. 3.8.4)
 $K_d = 0.85$ (Table 3.8.5.1)
 $G = 1.14$ (Sec. 3.8.6)
 $V = 120$ mph
 $C_d \text{ truss} = 1.25$ (Table 3.8.7-1)
 $P_z \text{ truss} = 44.65$ PSF
 $C_d \text{ panel} = 1.15$ (Table 3.8.7-1)
 $P_z \text{ panel} = 41.08$ PSF

Fatigue Loading (Ch. 11)

Galloping: N/A
 Natural Wind Gust: $P_{nw} = 5.2 \cdot C_d \cdot I_f$ (eq. 11.7.1.2-1)
 Importance factor $I_f = 1.00$ (sec. 11.6)
 $P_{nw} \text{ truss} = 6.50$ PSF
 $P_{nw} \text{ Panel} = 5.98$ PSF
 Truck Induced Gust: $P_{tg} = 18.8 \cdot C_d \cdot (V_t / 65 \text{ mph})^2 \cdot I_f$ (eq. C11.7.1.3-1)
 Importance factor $I_f = 1.00$ (sec. 11.6) $V_t = 25$ mph
 $P_{tg} \text{ truss} = 3.48$ PSF
 $P_{tg} \text{ Panel} = 3.20$ PSF

Check 3/8" Thru Bolt securing panel frame to mounting clips

Trib. Area= $.5(5.25 \text{ ft})(12.167 \text{ ft}) = 32 \text{ ft}^2$
 wind force= $(32 \text{ ft}^2)(41 \text{ psf}) = 1312 \text{ lbs}$
 dead load= $1.25(10 \text{ psf})(32 \text{ ft}^2) = 400 \text{ lbs}$

T per anchor= .400 k
 T capacity= $.75(45 \text{ ksi})(.11 \text{ in}^2) = 3.71 \text{ k}$ OK
 V per anchor= 1.31 k
 V capacity= $.75(27 \text{ ksi})(.11 \text{ in}^2) = 2.22 \text{ k}$ OK
 Fatigue load= $(32 \text{ ft}^2)(6 \text{ psf}) = 192 \text{ lbs}$
 A bolt= $.11 \text{ in}^2$
 Bolt Stress= $.192 \text{ k} / .11 \text{ in}^2 = 1.75 \text{ ksi} < 7 \text{ ksi Threshold}$ OK

Check 2"x4"x1/4" Mounting clip for panel frames, L= 3"

Bolt Bearing= 1.31 k
 $\Phi R_n = 2.4 \cdot D \cdot t \cdot F_u = 2.4(.375 \text{ in})(.25") (60 \text{ ksi}) = 13.5 \text{ k}$ OK
 Angle Leg Mu= $(.400 \text{ k})(3") = 1.20 \text{ k-in}$
 $Z = .25(3")(.25")^2 = .047 \text{ in}^3$
 $\phi M = \phi f_y Z = (.9)(36 \text{ ksi})(.047 \text{ in}^3) = 1.52 \text{ k-in}$ OK

Check 3/8" Thru Bolt securing EMC to Panel frame - (3) top and bottom - (6) total min.

EMC Area= $(5.667 \text{ ft})(10.667 \text{ ft}) = 61 \text{ ft}^2$
 wind force= $(61 \text{ ft}^2)(41 \text{ psf}) = 2501 \text{ lbs}$
 dead load= $1.25(10 \text{ psf})(61 \text{ ft}^2) = 763 \text{ lbs}$
 T per anchor= $.763 \text{ k} / 6 = .127 \text{ k}$
 T capacity= $.75(45 \text{ ksi})(.11 \text{ in}^2) = 3.71 \text{ k}$ OK
 V per anchor= $2.501 \text{ k} / 6 = .417 \text{ k}$
 V capacity= $.75(27 \text{ ksi})(.11 \text{ in}^2) = 2.22 \text{ k}$ OK
 Fatigue load= $(11 \text{ ft}^2)(6 \text{ psf}) = 66 \text{ lbs}$
 A bolt= $.11 \text{ in}^2$
 Bolt Stress= $.066 \text{ k} / .11 \text{ in}^2 = 0.60 \text{ ksi} < 7 \text{ ksi Threshold}$ OK

Check 3/8" Thru Bolt securing letters to mounting clips - (3) per letter min. - (2) OK for letter "I"

Area per letter= (2.50 ft)(2.50 ft) = 6.25 ft²
 wind force= (6.25 ft²)(41 psf)= 256 lbs
 dead load= 1.25(10 psf)(6.25 ft²)= 78 lbs

T per anchor= .078 k/3 = .026 k
 T capacity= .75(45 ksi)(.11 in²)= 3.71 k OK
 V per anchor= .256 k/3 = .085 k
 V capacity= .75(27 ksi)(.11 in²)= 2.22 k OK

Fatigue load= (6.25 ft²)(6 psf)/3= 13 lbs
 A bolt= .11 in²
 Bolt Stress= .013 k/.11 in² = 0.12 ksi < 7 ksi Threshold OK

PROJECT: Twin Falls Archway
 PROJ. NO.: 15975-1
 CLIENT: Lytle Signs

DATE: 7/24/18
 ENGINEER: JS

Version 3.0

Longitude Direction

			factored loads per RISA Report
applied shear at grade	v= 18 kip	unfactored load	30 k - Z per RISA Report
applied moment at grade	m= 374 kip-ft	unfactored load	622 k-ft Mx per RISA Report
depth of soil above footing	h _s = 0 ft		
allowable soil bearing	p= 2.7 ksf	(2000 x 1.33 = 2667)	
(use a factor of 1.33 for wind or seismic)			

Spread Footing Design

moment m=	482.0 k-ft	at base of footing			
Footing size (ft)	b= 12.00	L= 15.0	h= 6.00	S= 450.1	
Footing Weight=	162.0 k	signage weight=	31.0 k	soil 0.00	total= 193.00
Overturning;	M _c = 1448	M _c >1.5M	3.00		ok
soil pressure;	max= 2.143 ksf				ok
forces on concrete pad;	V= 144.7 k	V _r = 232 k	(=1.6V)		
	M= 543 k-ft	M _r = 868 k-ft			

Check Slab;

	φ= 0.9	f _y = 60 ksi	f _c = 2.5 ksi	150 lbs/ft ³
Flexure	A _s = 7.00	d= 68.0 in		
φM _n =φA _s f _y (d-a/2)=	25445 k-in	= 2120 k-ft		M _r <φM _n ok
a=A _s f _y /0.85f _c b=	1.373 in			

Check minimum A_{smin}=2sqrt(f_c)bd/f_y = 24.5 200bd/f_y= 32.64 or 1.333A_s= 9.33 in²
Use A_s= 9.33 in²

Shear; φV_n=φ2sqrt(f_c)bd φV_c= 734.4 φ= 0.75 V_r<φV_n ok

PROJECT: Twin Falls Archway
PROJ. NO.: 15975-1
CLIENT: Lytle Signs

DATE: 7/24/18
ENGINEER: JS

Version 3.0

Transverse Direction

units; pounds, feet unless noted otherwise

applied shear at grade $v = 19$ kip unfactored load X per RISA Report
applied moment at grade $m = 96$ kip-ft unfactored load Mz per RISA Report
depth of soil above footing $h_s = 0$ ft
allowable soil bearing $p = 2.0$ ksf

(use a factor of 1.33 for wind or seismic)

Spread Footing Design

moment $m = 210.0$ k-ft at base of footing
Footing size (ft) $b = 15.00$ $L = 12.0$ $h = 6.00$ $S = 360.1$
Footing Weight = 162.0 k signage weight = 31.0 k soil 0.00 total = 193.00
Overturning; $M_c = 1158$ $M_c > 1.5M$ 5.5143 ok
soil pressure; max = 1.655 ksf ok
forces on concrete pad; $V = 122.7$ k $V_f = 196$ k (=1.6V)
 $M = 368$ k-ft $M_f = 589$ k-ft

Check Slab;

$\phi = 0.9$ $f_y = 60$ ksi $f_c = 2.5$ ksi 150 lbs/ft3
Flexure $A_s = 4.00$ $d = 68.0$ in
 $\phi M_n = \phi A_s f_y (d - a/2) = 14620$ k-in = 1218 k-ft $M_r < \phi M_n$ ok
 $a = A_s f_y / 0.85 f_c b = 0.627$ in

Check minimum $A_{smin} = 2 \sqrt{f_c} b d / f_y = 30.6$ $200 b d / f_y = 40.80$ or $1.333 A_s = 5.33$ in²
Use $A_s = 5.33$ in²

Shear; $\phi V_n = \phi 2 \sqrt{f_c} b d$ $\phi V_c = 918.0$ $\phi = 0.75$ $V_r < \phi V_n$ ok

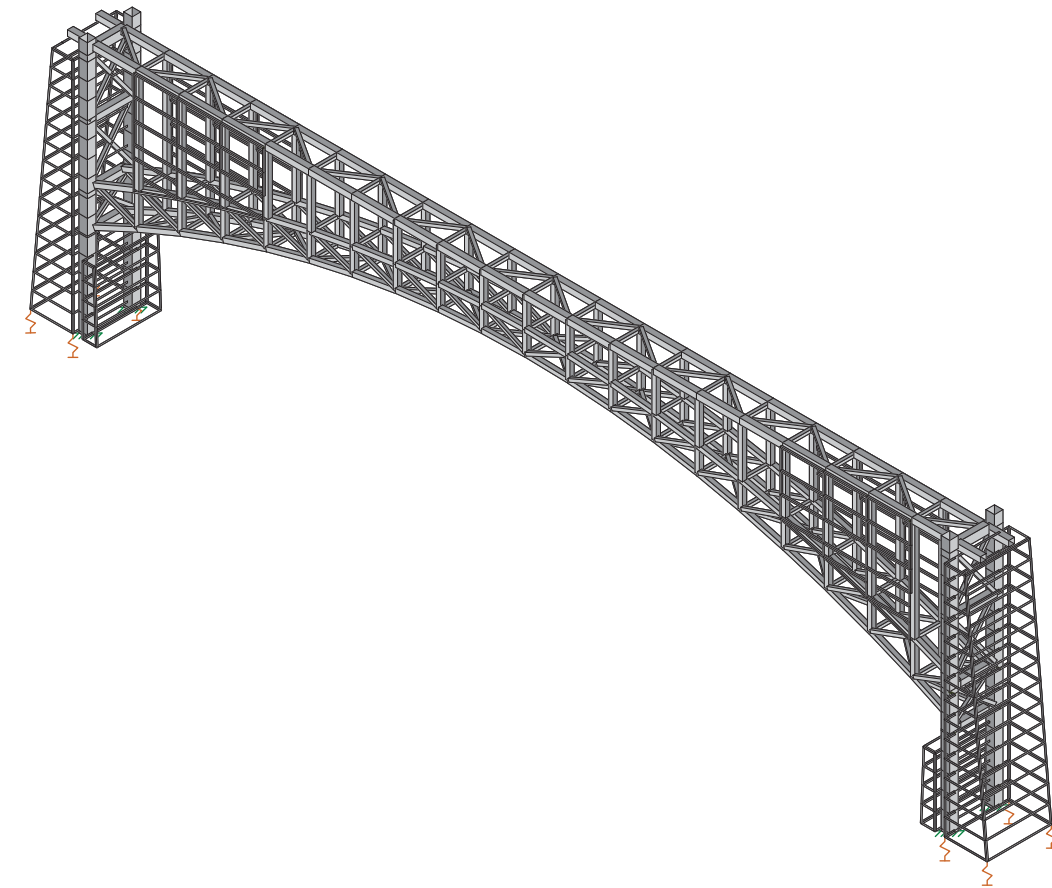
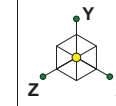

Envelope Only Solution

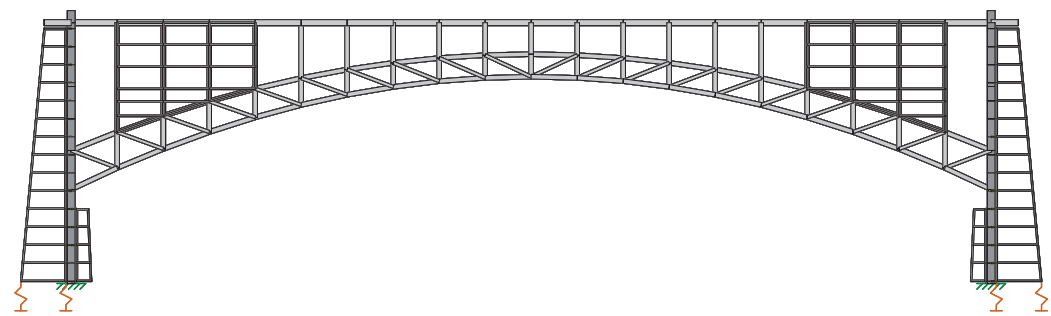

Envelope Only Solution

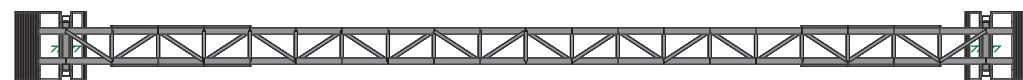

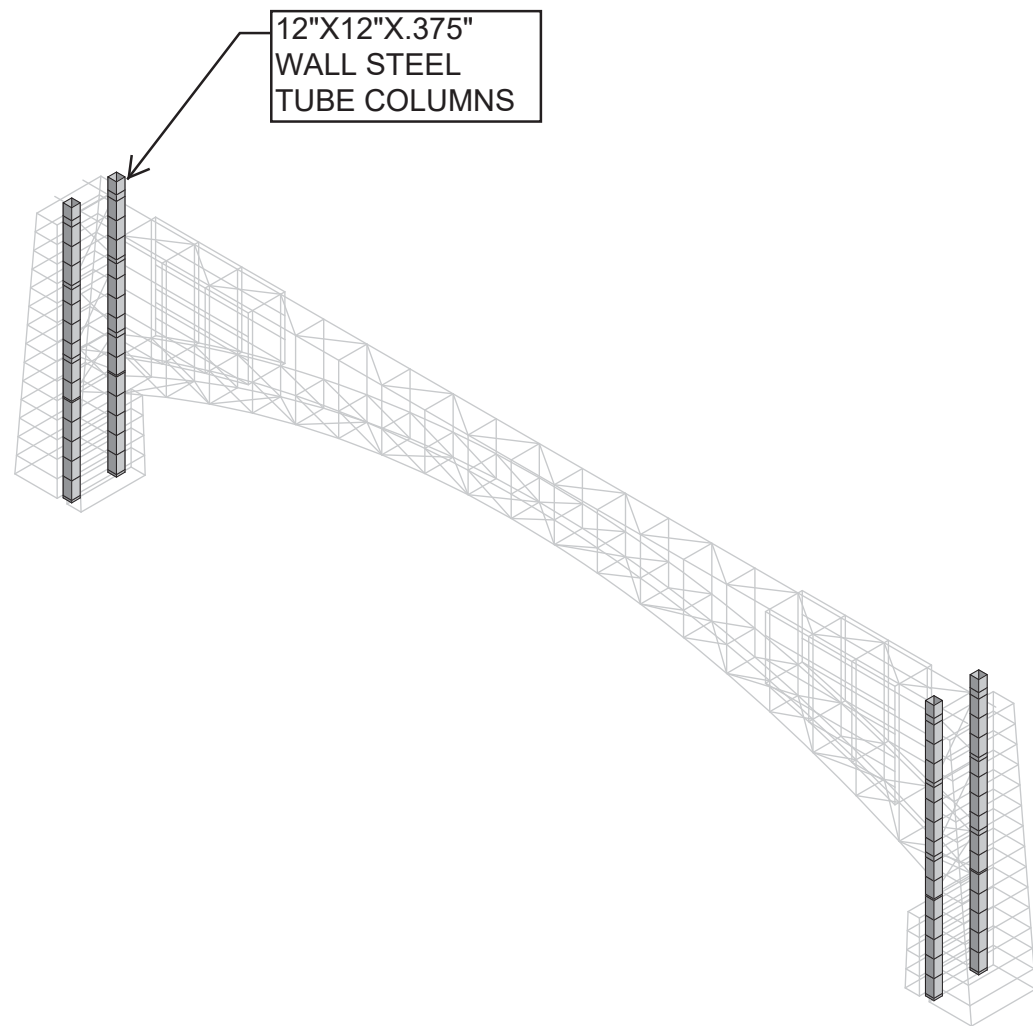
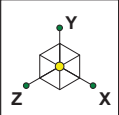

Envelope Only Solution

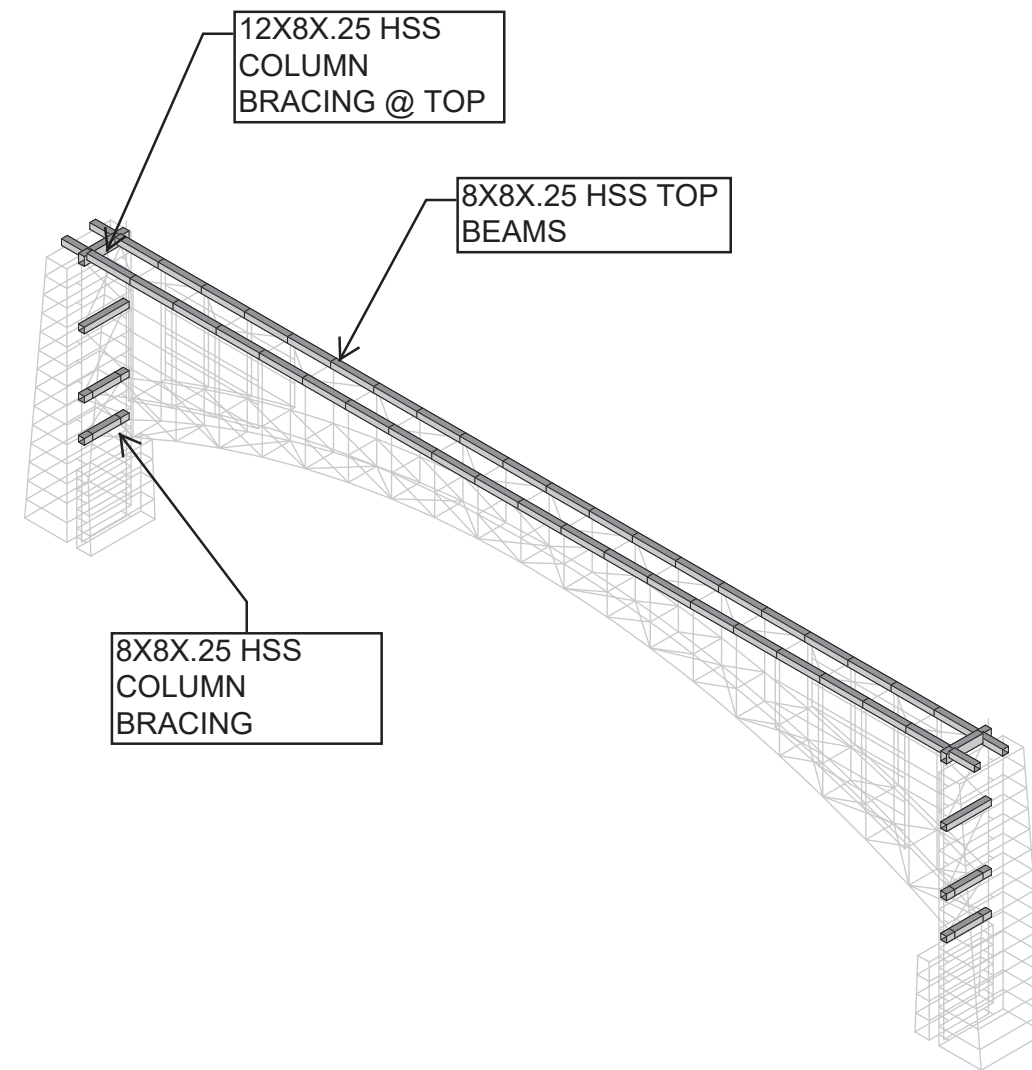
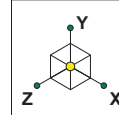

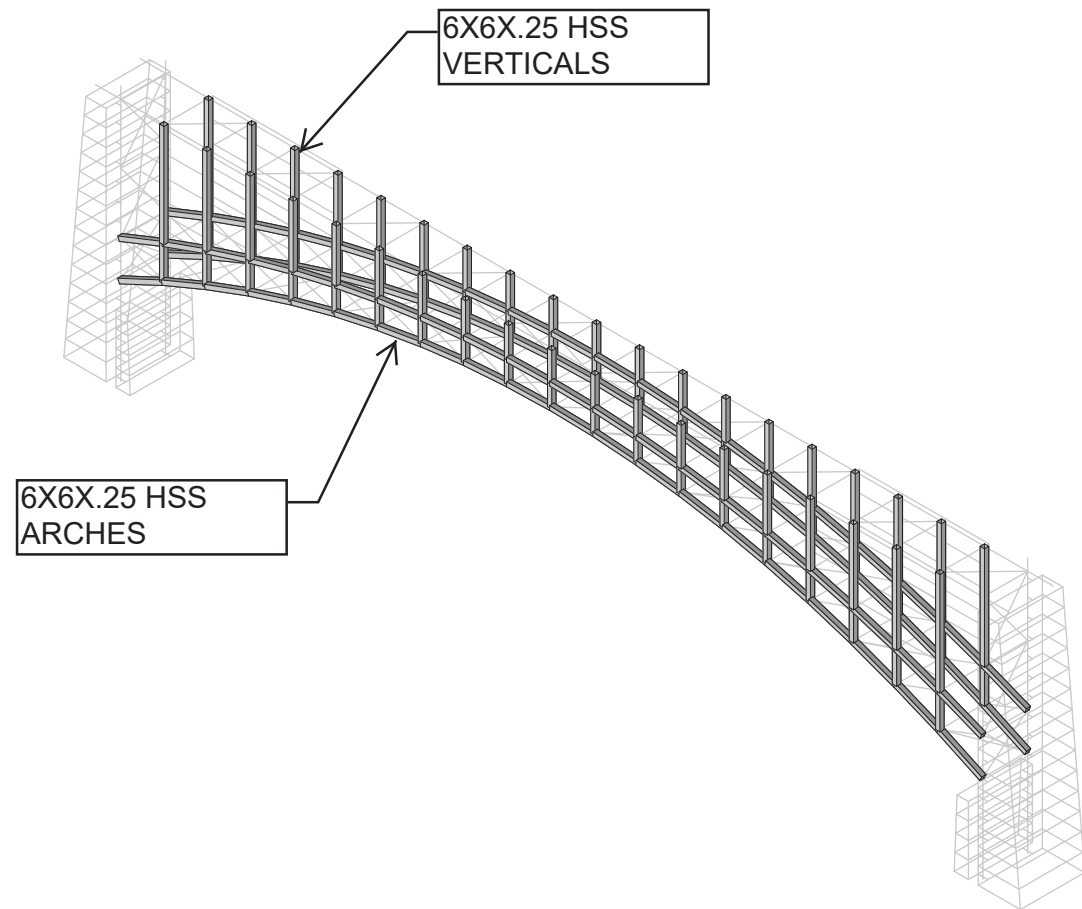
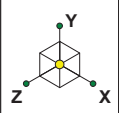

Envelope Only Solution

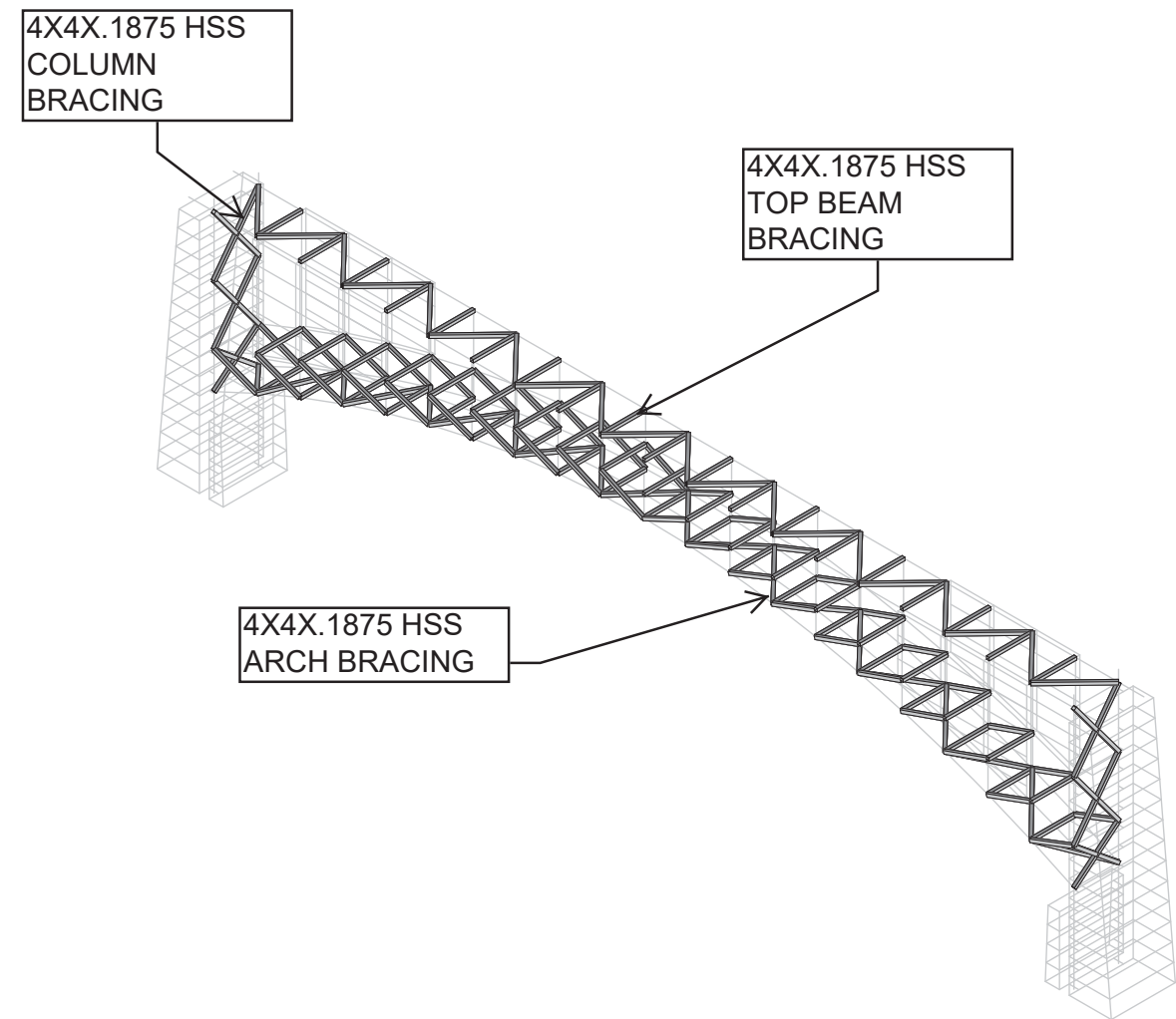
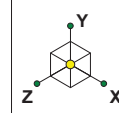

Envelope Only Solution

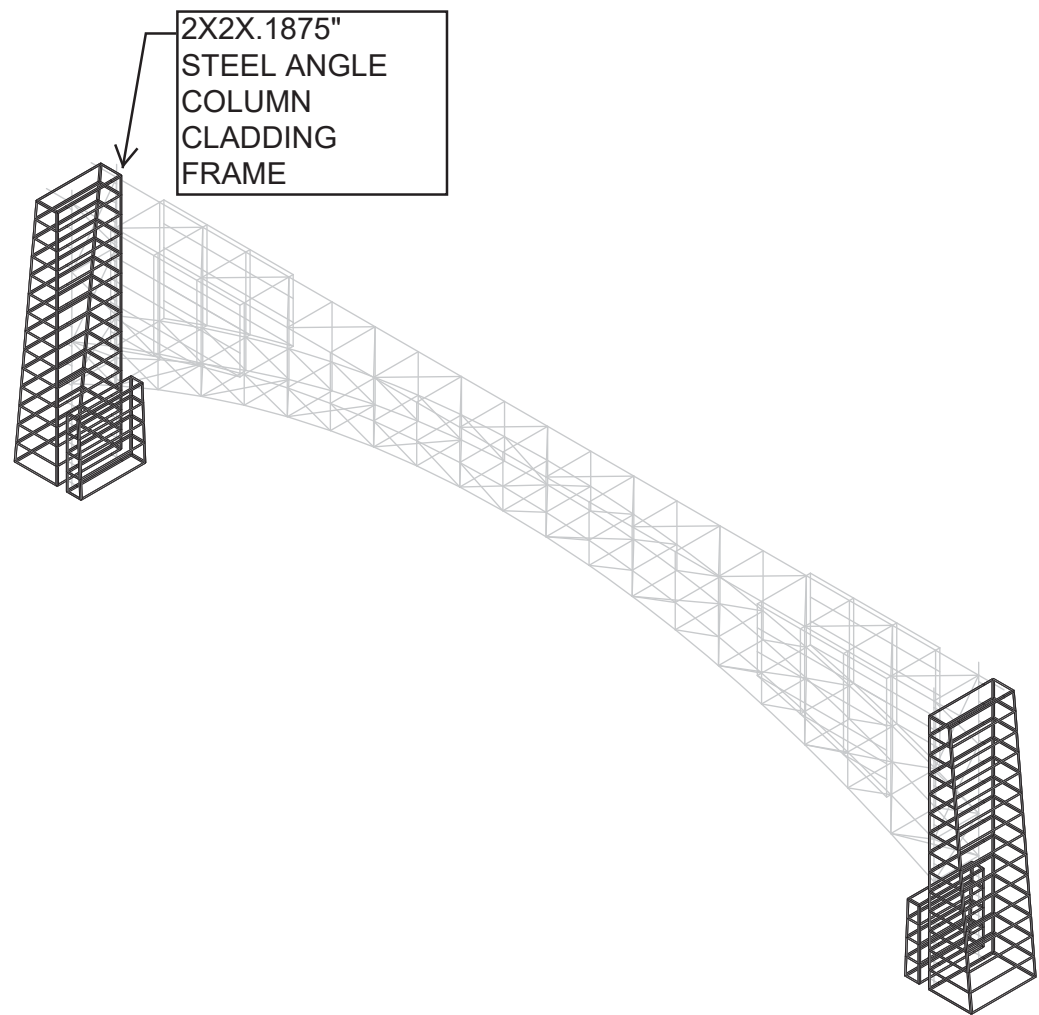
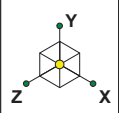

Envelope Only Solution

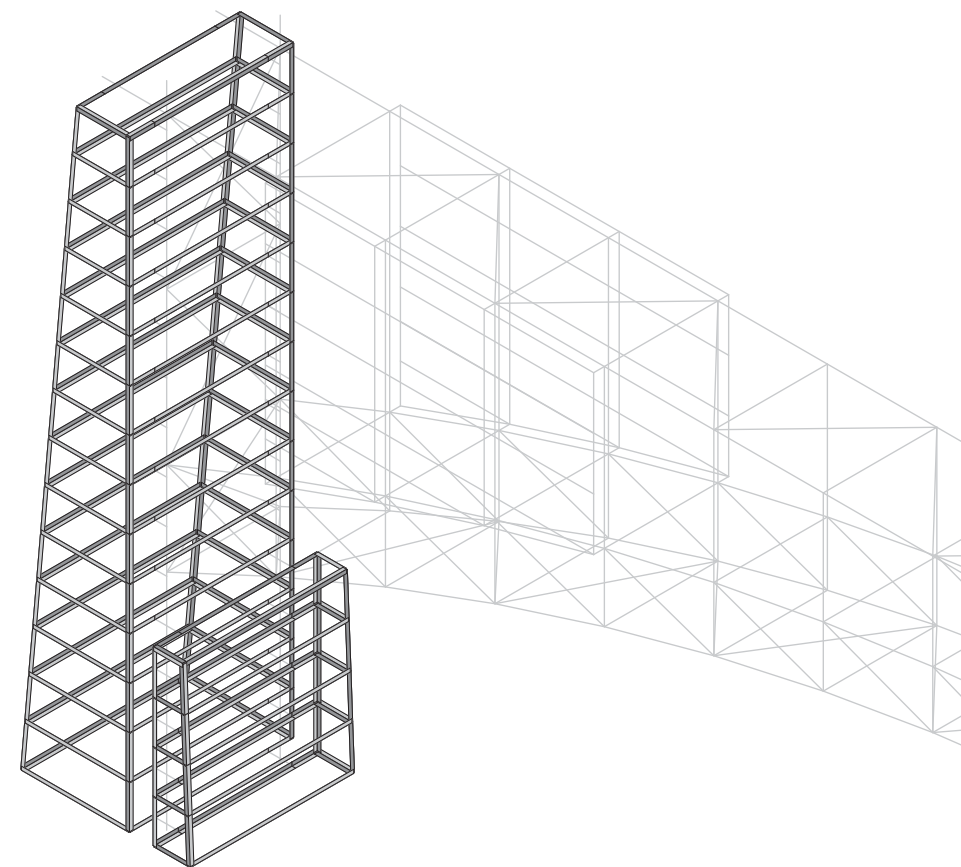
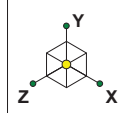

Envelope Only Solution

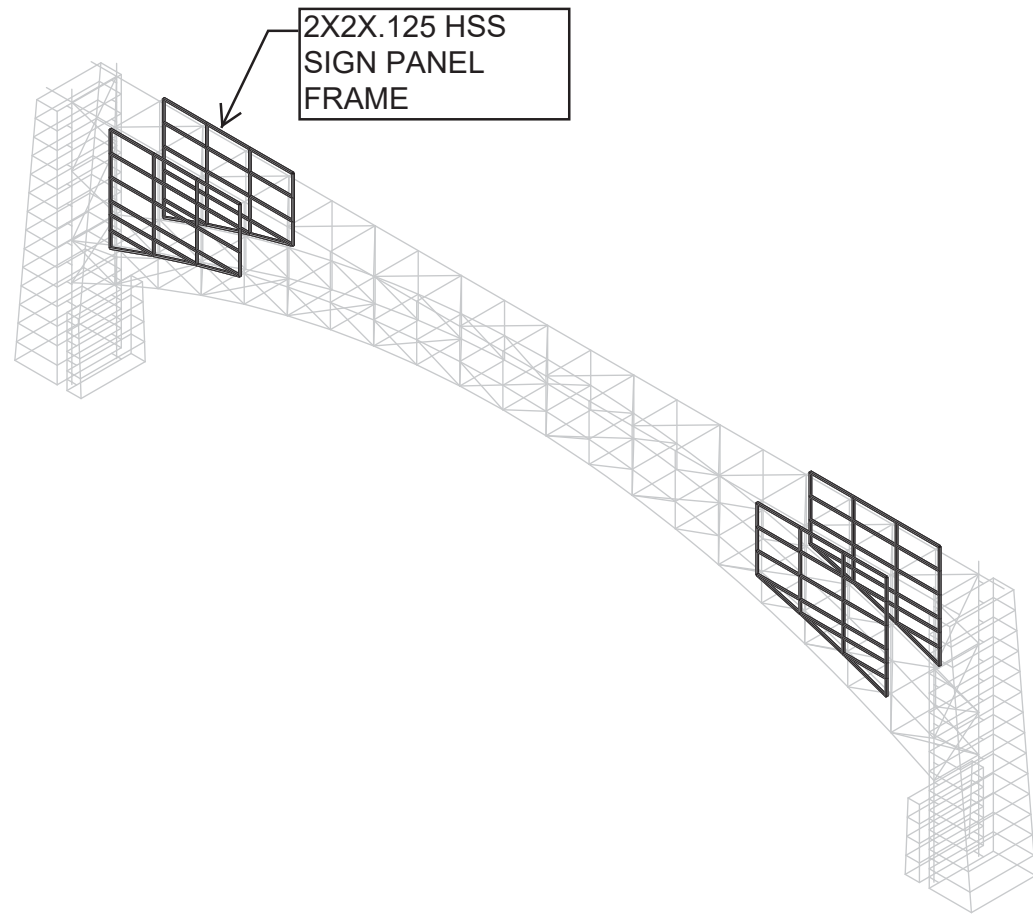
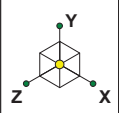

Envelope Only Solution

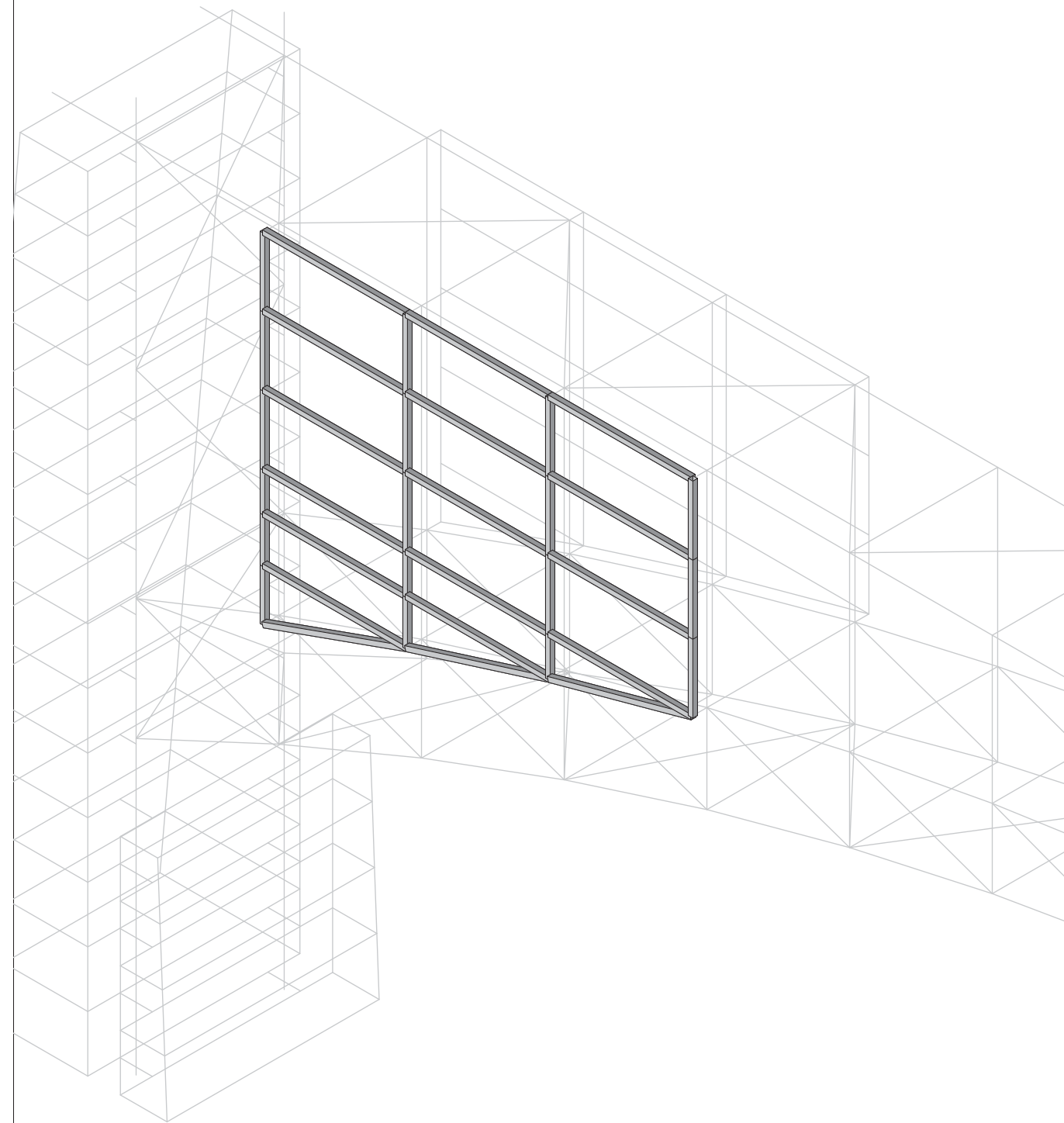
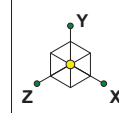

Envelope Only Solution

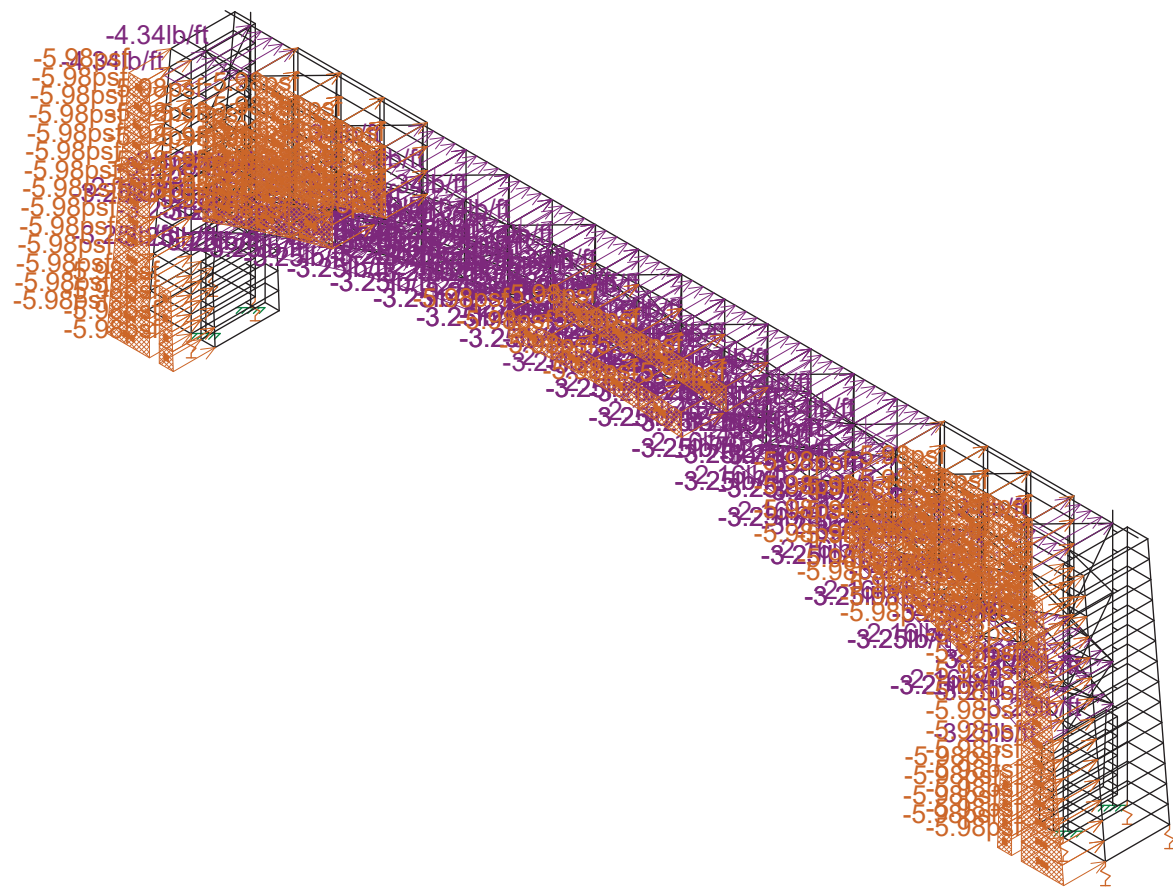
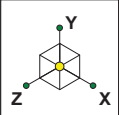

Loads: BLC 3, F
Envelope Only Solution

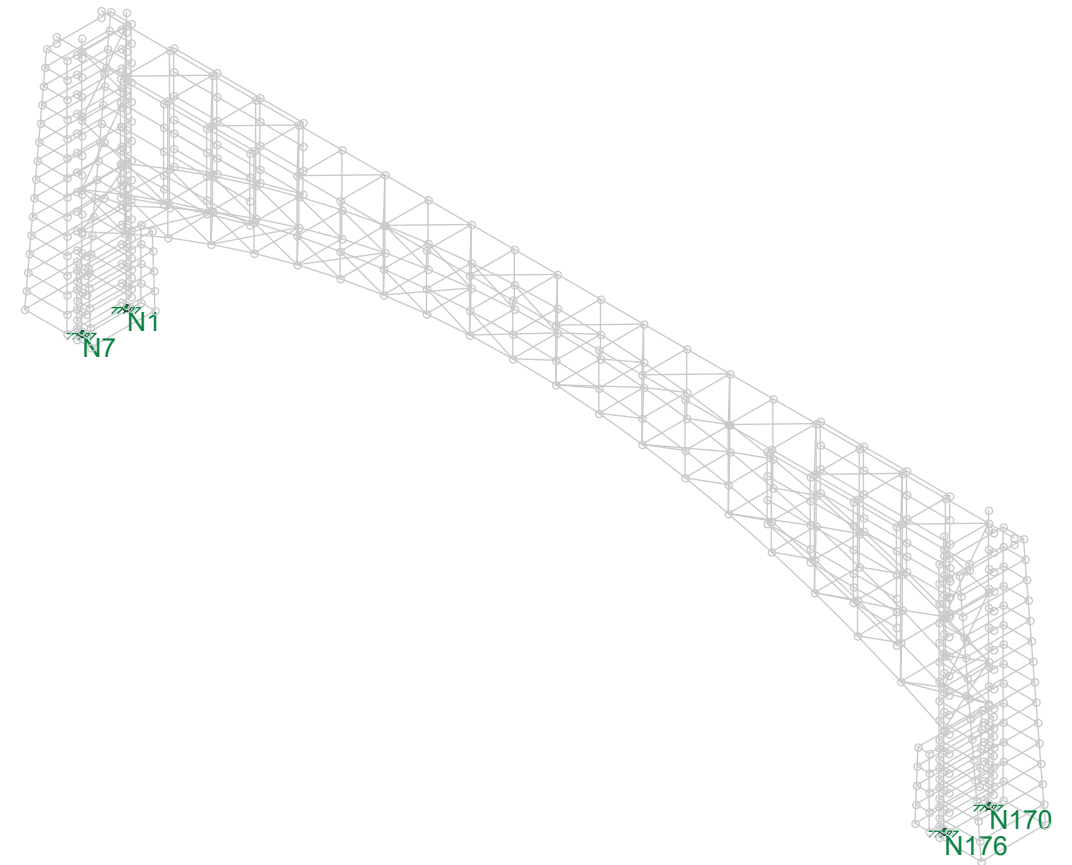
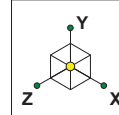

Envelope Only Solution

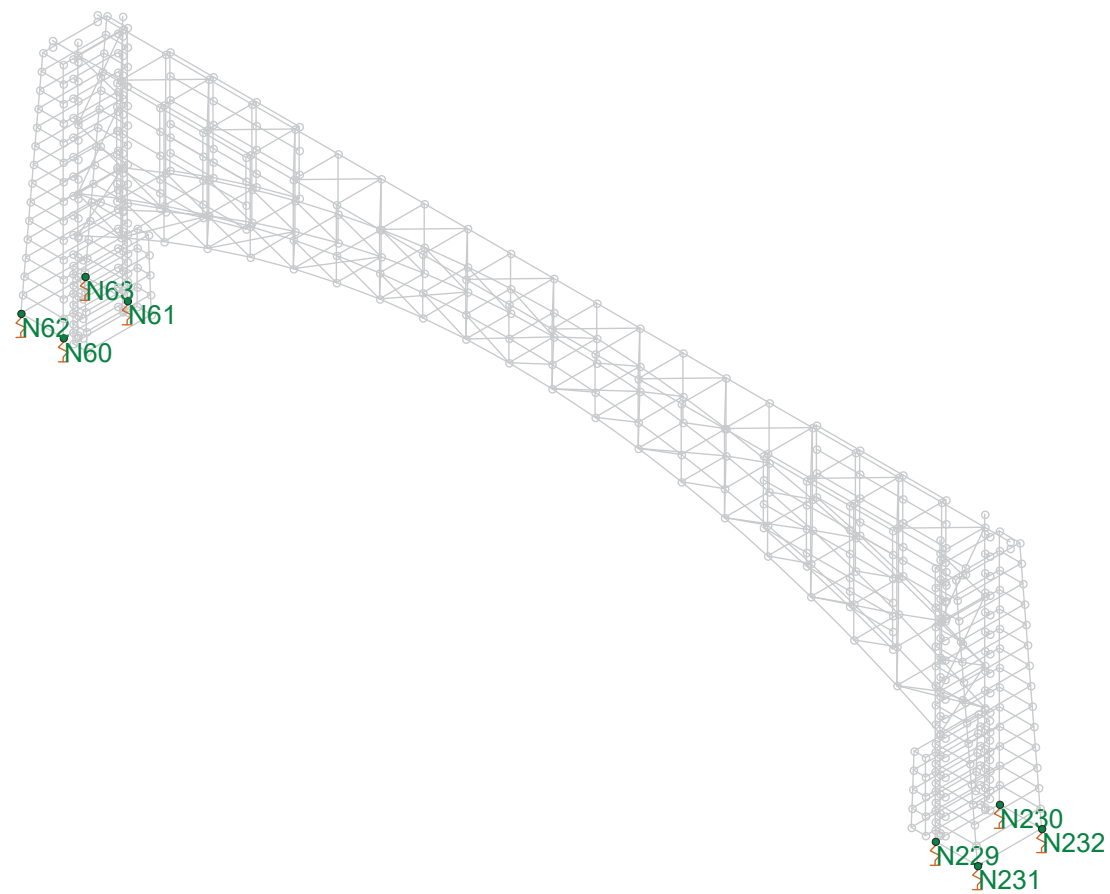
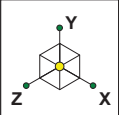

Envelope Only Solution

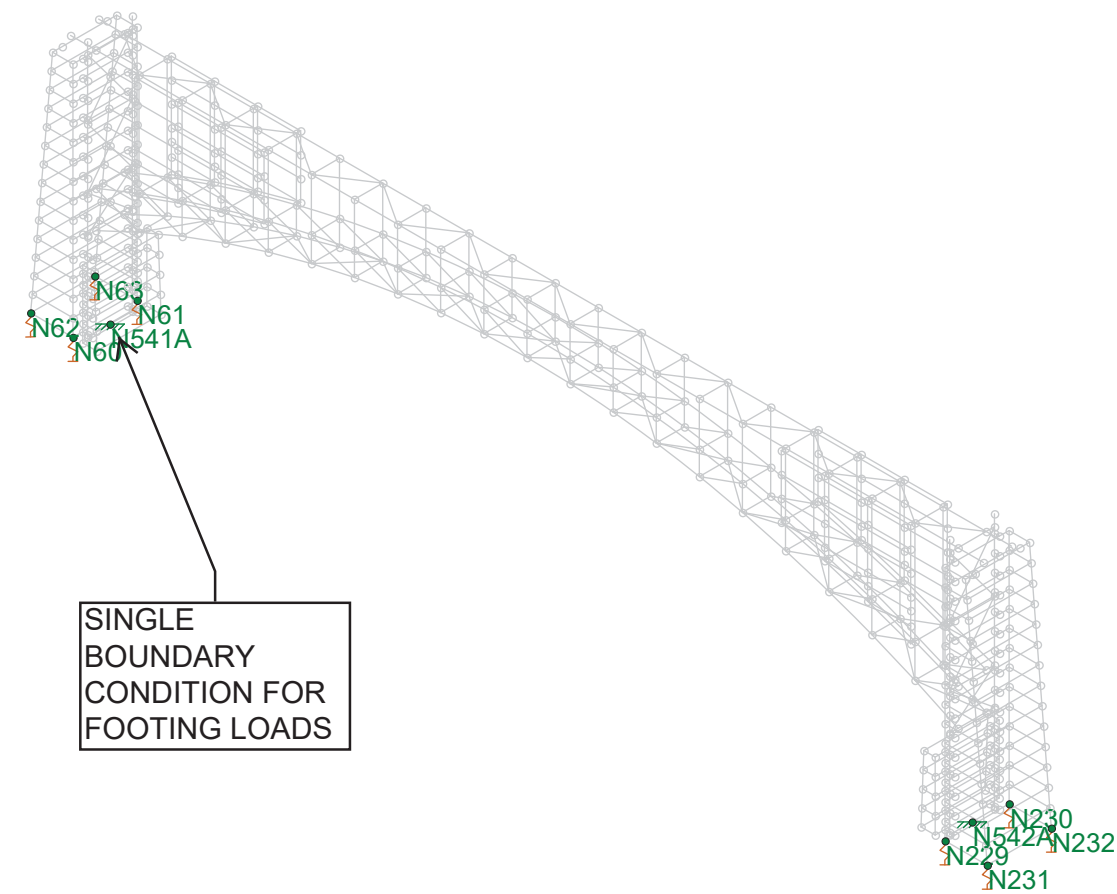
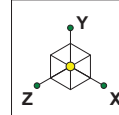

Envelope Only Solution

Hot Rolled Steel Properties

Label	E [ksi]	G [ksi]	Nu	Therm (\1E..Density[k/ft...	Yield[ksi]	Ry	Fu[ksi]	Rt		
1	A992	29000	11154	.3	.65	.49	50	1.1	65	1.1
2	A36 Gr.36	29000	11154	.3	.65	.49	36	1.5	58	1.2
3	A572 Gr.50	29000	11154	.3	.65	.49	50	1.1	65	1.1
4	A500 Gr.B RND	29000	11154	.3	.65	.527	42	1.4	58	1.3
5	A500 Gr.B Rect	29000	11154	.3	.65	.527	46	1.4	58	1.3
6	A53 Gr.B	29000	11154	.3	.65	.49	35	1.6	60	1.2
7	A1085	29000	11154	.3	.65	.49	50	1.4	65	1.3

Hot Rolled Steel Section Sets

Label	Shape	Type	Design List	Material	Design R...	A [in2]	Iyy [in4]	Izz [in4]	J [in4]
1	8X8X.25 HSS	Beam	SquareTube	A500 Gr.B Rect	Typical	7.1	70.7	70.7	111
2	6X6X.25 HSS	Beam	SquareTube	A500 Gr.B Rect	Typical	5.24	28.6	28.6	45.6
3	4X4X.1875 HSS	Beam	SquareTube	A500 Gr.B Rect	Typical	2.58	6.21	6.21	10
4	12X12X.375 TUBE	Beam	SquareTube	A500 Gr.B Rect	Typical	16	357	357	561
5	L2X2X.1875	Beam	Single Angle	A36 Gr.36	Typical	.722	.271	.271	.009
6	2X2X.188 HSS	Beam	SquareTube	A500 Gr.B Rect	Typical	1.19	.641	.641	1.09
7	12X8X.25 HSS	Beam	SquareTube	A500 Gr.B Rect	Typical	8.96	98.8	184	202

Basic Load Cases

BLC Description	Category	X Gravity	Y Gravity	Z Gravity	Joint	Point	DistributedArea(Me... Surface(...
1	D	DL	-1				180
2	W	WL				200	104
3	F	None				200	104
4	BLC 1 Transient Ar...	None				690	
5	BLC 2 Transient Ar...	None				417	
6	BLC 3 Transient Ar...	None				417	

Load Combinations

Description	So...	PDelta	S...	BLCFac...	BLCFac...	BLCFac...	BLCFac...	BLCFac...	BLCFac...	BLCFac...	BLCFac...
1	D	Yes	Y	1	1						
2	W	Yes	Y	2	1						
3	F	Yes	Y	3	1						
4	1.25D	Yes	Y	1	1.25						
5	1.1D+1.0W	Yes	Y	1	1.1	2	1				
6	0.9D+1.0W	Yes	Y	1	.9	2	1				
7	1.0D+1.0F	Yes	Y	1	1	3	1				

Envelope Joint Reactions

Joint	X [k]	LC	Y [k]	LC	Z [k]	LC	MX [k-ft]	LC	MY [k-ft]	LC	MZ [k-ft]	LC		
1	N7	max	9.385	4	19.433	4	15.313	5	87.944	2	-529	1	37.703	2
2		min	-6.456	2	-85.862	2	.316	1	-19.587	4	-47.691	4		
3	N1	max	14.78	5	100.044	5	14.351	2	87.445	5	.769	4	-5.503	3
4		min	.966	3	12.038	3	-.395	4	.14	1	-19.132	2	-80.416	5
5	N170	max	-.966	3	100.034	5	14.351	2	87.446	5	19.132	2	80.417	5
6		min	-14.78	5	12.038	3	-.395	4	.14	1	-.768	4	5.503	3
7	N176	max	6.456	2	19.446	4	15.313	5	87.944	2	19.588	5	47.69	4
8		min	-9.385	4	-85.863	2	.316	1	-.27	4	.53	1	-37.703	2
9	N62	max	0	1	5.006	4	0	1	0	1	0	1	0	1
10		min	0	1	0	2	0	1	0	1	0	1	0	1
11	N63	max	0	1	5.679	5	0	1	0	1	0	1	0	1
12		min	0	1	.176	3	0	1	0	1	0	1	0	1
13	N60	max	0	1	.612	4	0	1	0	1	0	1	0	1

Envelope Joint Reactions (Continued)

Joint	X [k]	LC	Y [k]	LC	Z [k]	LC	MX [k-ft]	LC	MY [k-ft]	LC	MZ [k-ft]	LC
14		min	0	1	0	2	0	1	0	1	0	1
15	N61	max	0	1	2.493	5	0	1	0	1	0	1
16		min	0	1	.285	3	0	1	0	1	0	1
17	N230	max	0	1	2.493	5	0	1	0	1	0	1
18		min	0	1	.285	3	0	1	0	1	0	1
19	N232	max	0	1	5.685	5	0	1	0	1	0	1
20		min	0	1	.176	3	0	1	0	1	0	1
21	N231	max	0	1	4.997	4	0	1	0	1	0	1
22		min	0	1	0	2	0	1	0	1	0	1
23	N229	max	0	1	.612	4	0	1	0	1	0	1
24		min	0	1	0	2	0	1	0	1	0	1
25	Totals:	max	0	5	100.282	4	58.553	6				
26		min	0	3	0	3	0	4				

Envelope AISC 14th(360-10): LRFD Steel Code Checks

Member	Shape	Code Check	Lo...	LC	Shear ...	Lo...	phi*P...	phi*P...	phi*Mn...	phi*Mn...	Eqn		
1	M1	HSS12x12x6	.827	0	5	.173	0	z 5	662.3...	662.4	223.27	223.27	... H1-1b
2	M2	HSS12x12x6	.000	0	4	.000	0	y 5	661.8...	662.4	223.27	223.27	1 H1-1b
3	M3	HSS12x12x6	.428	0	5	.177	0	z 5	661.4...	662.4	223.27	223.27	... H1-1b
4	M4	HSS12x12x6	.072	0	5	.041	0	y 2	661.7...	662.4	223.27	223.27	... H1-1b
5	M5	HSS12x12x6	.041	0	5	.043	0	y 5	662.35	662.4	223.27	223.27	... H1-1b
6	M6	HSS12x12x6	.628	0	2	.180	0	y 5	662.3...	662.4	223.27	223.27	... H1-1b
7	M7	HSS12x12x6	.000	0	4	.000	0	y 5	661.8...	662.4	223.27	223.27	1 H1-1b
8	M8	HSS12x12x6	.274	0	2	.111	0	y 2	661.4...	662.4	223.27	223.27	... H1-1b
9	M9	HSS12x12x6	.062	0	2	.043	0	y 5	661.7...	662.4	223.27	223.27	... H1-1b
10	M10	HSS12x12x6	.036	0	2	.043	0	y 2	662.35	662.4	223.27	223.27	... H1-1b
11	M11	HSS12x8x4	.153	0	5	.097	0	y 5	326.7...	370.9...	73.797	116.951	... H1-1b
12	M12	HSS8x8x4	.261	0	5	.218	0	z 5	293.6...	293.94	66.288	66.288	... H1-1b
13	M13	HSS8x8x4	.532	0	5	.492	0	z 5	293.6...	293.94	66.288	66.288	... H1-1b
14	M14	HSS8x8x4	.078	63.5	5	.048	0	y 5	286.0...	293.94	66.288	66.288	... H1-1b
15	M15	HSS4x4x3	.082	53...	5	.004	0	z 2	98.733	106.8...	12.662	12.662	... H1-1b
16	M16	HSS4x4x3	.078	53...	5	.003	53...	y 5	98.733	106.8...	12.662	12.662	... H1-1b
17	M17	HSS4x4x3	.243	41...	2	.015	0	y 2	101.9...	106.8...	12.662	12.662	... H1-1a
18	M18	HSS4x4x3	.410	41...	2	.045	0	y 5	101.9...	106.8...	12.662	12.662	... H1-1a
19	M19	HSS4x4x3	.079	53...	2	.010	0	y 5	98.733	106.8...	12.662	12.662	... H1-1b
20	M20	HSS4x4x3	.076	53...	2	.009	0	y 5	98.733	106.8...	12.662	12.662	... H1-1b
21	M21	HSS4x4x3	.105	0	5	.008	0	z 2	98.733	106.8...	12.662	12.662	... H1-...
22	M22	HSS4x4x3	.103	0	5	.006	0	z 5	98.733	106.8...	12.662	12.662	... H1-...
23	M23	HSS4x4x3	.125	0	5	.009	0	y 5	98.733	106.8...	12.662	12.662	... H1-...
24	M24	HSS4x4x3	.123	0	5	.003	53...	y 5	98.733	106.8...	12.662	12.662	... H1-...
25	M25	HSS4x4x3	.456	0	5	.029	0	y 2	101.9...	106.8...	12.662	12.662	... H1-1a
26	M26	HSS4x4x3	.257	0	5	.019	41...	y 5	101.9...	106.8...	12.662	12.662	... H1-1a
27	M29	HSS12x12x6	.600	0	2	.182	0	y 5	661.2...	662.4	223.27	223.27	... H1-1b
28	M30	HSS12x12x6	.791	0	5	.175	0	y 2	661.2...	662.4	223.27	223.27	... H1-1b
29	M31	HSS12x12x6	.409	0	2	.180	0	y 5	661.2...	662.4	223.27	223.27	... H1-1b
30	M32	HSS12x12x6	.231	0	2	.181	0	y 5	661.2...	662.4	223.27	223.27	... H1-1b
31	M33	HSS12x12x6	.247	24	2	.182	0	y 5	661.2...	662.4	223.27	223.27	... H1-1b
32	M34	HSS12x12x6	.420	24	2	.189	0	y 5	661.2...	662.4	223.27	223.27	... H1-1b
33	M35	HSS12x12x6	.534	0	5	.173	0	y 2	661.2...	662.4	223.27	223.27	... H1-1b
34	M36	HSS12x12x6	.286	0	5	.173	0	y 2	661.2...	662.4	223.27	223.27	... H1-1b
35	M37	HSS12x12x6	.363	24	5	.173	0	y 2	661.2...	662.4	223.27	223.27	... H1-1b
36	M38	HSS12x12x6	.619	24	5	.177	0	y 2	661.2...	662.4	223.27	223.27	... H1-1b
37	M49	L2x2x3	.471	13...	5	.064	0	z 5	21.904	23.393	.558	1.239	... H2-1
38	M50	L2x2x3	.453	0	5	.022	0	y 5	6.121	23.393	.558	1.196	... H2-1
39	M51	L2x2x3	.585	0	5	.075	0	y 5	21.904	23.393	.558	1.239	... H2-1
40	M52	L2x2x3	.556	13...	4	.080	13...	z 4	21.904	23.393	.558	1.239	... H2-1
41	M53	L2x2x3	.420	0	5	.019	0	z 5	6.121	23.393	.558	1.197	... H2-1
42	M54	L2x2x3	.697	0	5	.094	0	z 5	21.904	23.393	.558	1.239	... H2-1

Envelope AISC 14th(360-10): LRFD Steel Code Checks (Continued)

Member	Shape	Code Check	Lo...	LC	Shear ...	Lo...	phi*P...	phi*P...	phi*Mn...	phi*Mn...	Eqn			
43	M55	L2x2x3	.560	13...	4	.074	13...	z 4	21.904	23.393	.558	1.239	...	H2-1
44	M56	L2x2x3	.372	0	5	.017	0	z 5	6.121	23.393	.558	1.197	...	H2-1
45	M57	L2x2x3	.576	0	5	.076	0	z 5	21.904	23.393	.558	1.239	...	H2-1
46	M58	L2x2x3	.651	13...	5	.075	13...	z 5	21.904	23.393	.558	1.239	...	H2-1
47	M59	L2x2x3	.244	0	5	.011	0	z 5	6.121	23.393	.558	1.197	...	H2-1
48	M60	L2x2x3	.482	0	4	.061	0	z 4	21.904	23.393	.558	1.239	...	H2-1
49	M61	L2x2x3	.856	13...	5	.085	13...	z 5	21.904	23.393	.558	1.239	...	H2-1
50	M62	L2x2x3	.041	0	5	.002	0	z 5	6.121	23.393	.558	1.203	...	H2-1
51	M63	L2x2x3	.588	0	2	.066	0	z 2	21.904	23.393	.558	1.239	...	H2-1
52	M64	L2x2x3	.306	16	4	.056	0	y 4	21.399	23.393	.558	1.239	...	H2-1
53	M65	L2x2x3	.396	16	5	.058	0	z 5	21.399	23.393	.558	1.239	...	H2-1
54	M66	L2x2x3	.211	0	4	.023	24...	y 5	19.138	23.393	.558	1.239	...	H2-1
55	M67	L2x2x3	.292	0	5	.022	0	z 4	19.138	23.393	.558	1.239	...	H2-1
56	M68	L2x2x3	.705	0	5	.033	0	z 5	2.981	23.393	.558	1.094	...	H2-1
57	M69	L2x2x3	.354	0	5	.019	0	y 5	2.981	23.393	.558	1.088	...	H2-1
58	M70	L2x2x3	.207	20	4	.028	0	z 4	20.354	23.393	.558	1.239	...	H2-1
59	M71	L2x2x3	.219	0	5	.036	0	y 5	20.354	23.393	.558	1.239	...	H2-1
60	M72	L2x2x3	.285	24	2	.027	24	z 2	19.145	23.393	.558	1.239	...	H2-1
61	M73	L2x2x3	.218	0	5	.023	0	y 4	19.145	23.393	.558	1.239	...	H2-1
62	M74	L2x2x3	.233	24	4	.028	0	z 5	19.145	23.393	.558	1.239	...	H2-1
63	M75	L2x2x3	.259	24	5	.030	0	z 5	19.145	23.393	.558	1.239	...	H2-1
64	M76	L2x2x3	.382	0	5	.034	0	y 5	19.145	23.393	.558	1.239	...	H2-1
65	M77	L2x2x3	.216	0	4	.023	0	z 4	19.145	23.393	.558	1.239	...	H2-1
66	M78	L2x2x3	.279	24	5	.026	0	z 4	19.145	23.393	.558	1.239	...	H2-1
67	M79	L2x2x3	.322	24	5	.023	0	z 5	19.145	23.393	.558	1.239	...	H2-1
68	M80	L2x2x3	.222	0	4	.024	0	y 4	19.138	23.393	.558	1.239	...	H2-1
69	M81	L2x2x3	.223	24...	4	.026	0	z 4	19.138	23.393	.558	1.239	...	H2-1
70	M82	L2x2x3	.349	24...	4	.038	0	y 4	19.138	23.393	.558	1.239	...	H2-1
71	M83	L2x2x3	.341	0	5	.030	.25	z 5	19.138	23.393	.558	1.239	...	H2-1
72	M84	L2x2x3	.298	0	5	.032	2.5...	z 5	19.138	23.393	.558	1.239	...	H2-1
73	M85	L2x2x3	.464	24...	5	.050	.25	z 5	19.138	23.393	.558	1.239	...	H2-1
74	M86	L2x2x3	.517	0	4	.062	0	z 4	21.155	23.393	.558	1.239	...	H2-1
75	M87	L2x2x3	.545	18	4	.063	0	z 4	20.899	23.393	.558	1.239	...	H2-1
76	M88	L2x2x3	.426	19	4	.050	0	z 4	20.632	23.393	.558	1.239	...	H2-1
77	M89	L2x2x3	.426	19	4	.050	0	y 4	20.632	23.393	.558	1.239	...	H2-1
78	M90	L2x2x3	.553	18	5	.063	0	y 4	20.899	23.393	.558	1.239	...	H2-1
79	M91	L2x2x3	.553	17	5	.062	0	y 4	21.155	23.393	.558	1.239	...	H2-1
80	M92	L2x2x3	.742	0	5	.036	0	y 5	2.981	23.393	.558	1.12	...	H2-1
81	M93	L2x2x3	.722	0	5	.035	0	y 5	2.981	23.393	.558	1.113	...	H2-1
82	M94	L2x2x3	.672	0	5	.034	0	y 5	2.981	23.393	.558	1.109	...	H2-1
83	M95	L2x2x3	.625	13...	5	.088	13...	y 5	21.904	23.393	.558	1.239	...	H2-1
84	M96	L2x2x3	.037	0	5	.002	0	y 5	6.121	23.393	.558	1.2	...	H2-1
85	M97	L2x2x3	.670	0	2	.072	0	y 2	21.904	23.393	.558	1.239	...	H2-1
86	M100	L2x2x3	.504	0	5	.027	60	z 5	6.856	23.393	.558	1.147	...	H2-1
87	M101	L2x2x3	.355	91	5	.016	0	z 5	2.981	23.393	.558	1.124	...	H2-1
88	M102	L2x2x3	.383	0	2	.032	0	z 6	6.856	23.393	.558	1.136	...	H2-1
89	M103	HSS12x12x6	.641	2	5	.178	0	y 2	662.3...	662.4	223.27	223.27	...	H1-1b
90	M104	HSS12x12x6	.433	2	2	.186	0	y 5	662.3...	662.4	223.27	223.27	...	H1-1b
91	M105	HSS12x12x6	.255	0	5	.177	0	z 5	661.2...	662.4	223.27	223.27	...	H1-1b
92	M106	HSS12x12x6	.087	0	5	.179	0	z 5	662.3...	662.4	223.27	223.27	...	H1-1b
93	M107	HSS12x12x6	.168	0	2	.113	0	y 2	661.2...	662.4	223.27	223.27	...	H1-1b
94	M108	HSS12x12x6	.065	0	5	.116	0	y 2	662.3...	662.4	223.27	223.27	...	H1-1b
95	M109	HSS12x12x6	.060	0	5	.042	0	y 2	661.2...	662.4	223.27	223.27	...	H1-1b
96	M110	HSS12x12x6	.052	0	2	.044	0	y 5	661.2...	662.4	223.27	223.27	...	H1-1b
97	M111	HSS12x12x6	.049	0	5	.043	0	y 2	661.2...	662.4	223.27	223.27	...	H1-1b
98	M112	HSS12x12x6	.048	0	5	.044	0	z 2	661.6...	662.4	223.27	223.27	...	H1-1b
99	M113	HSS12x12x6	.041	0	2	.045	0	y 5	661.2...	662.4	223.27	223.27	...	H1-1b
100	M114	HSS12x12x6	.031	0	2	.046	0	y 5	661.6...	662.4	223.27	223.27	...	H1-1b
101	M115	HSS12x12x6	.036	0	5	.043	0	y 5	661.2...	662.4	223.27	223.27	...	H1-1b

Envelope AISC 14th(360-10): LRFD Steel Code Checks (Continued)

Member	Shape	Code Check	Lo...	LC	Shear ...	Lo...	phi*P...	phi*P...	phi*Mn...	phi*Mn...	Eqn			
102	M116	HSS12x12x6	.032	0	2	.043	0	y 2	661.2...	662.4	223.27	223.27	...	H1-1b
103	M117	HSS12x12x6	.029	24	5	.044	0	z 5	661.2...	662.4	223.27	223.27	...	H1-1b
104	M118	HSS12x12x6	.052	24	5	.045	0	z 5	661.2...	662.4	223.27	223.27	...	H1-1b
105	M119	HSS12x12x6	.025	24	2	.043	0	y 2	661.2...	662.4	223.27	223.27	...	H1-1b
106	M120	HSS12x12x6	.043	24	2	.044	0	z 2	661.2...	662.4	223.27	223.27	...	H1-1b
107	M121	HSS12x12x6	.060	8	5	.045	0	y 2	662.2...	662.4	223.27	223.27	...	H1-1b
108	M122	HSS12x12x6	.049	8	2	.047	0	z 5	662.2...	662.4	223.27	223.27	...	H1-1b
109	M123	L2x2x3	.420	0	2	.021	13...	y 4	21.904	23.393	.558	1.239	...	H2-1
110	M124	L2x2x3	.190	63.5	2	.011	0	y 5	6.121	23.393	.558	1.195	...	H2-1
111	M125	L2x2x3	.545	13...	5	.030	0	y 2	21.904	23.393	.558	1.239	...	H2-1
112	M128	L2x2x3	.658	13...	5	.076	0	y 5	21.904	23.393	.558	1.239	...	H2-1
113	M129	L2x2x3	.267	0	5	.015	0	y 5	6.121	23.393	.558	1.194	...	H2-1
114	M130	L2x2x3	.649	13...	5	.057	0	y 5	21.904	23.393	.558	1.239	...	H2-1
115	M133	L2x2x3	.829	13...	5	.098	0	y 5	21.904	23.393	.558	1.239	...	H2-1
116	M134	L2x2x3	.290	0	5	.015	0	y 5	6.121	23.393	.558	1.192	...	H2-1
117	M135	L2x2x3	.670	13...	5	.074	0	y 5	21.904	23.393	.558	1.239	...	H2-1
118	M138	L2x2x3	.718	13...	2	.083	0	y 5	21.904	23.393	.558	1.239	...	H2-1
119	M139	L2x2x3	.259	0	5	.012	0	y 5	6.121	23.393	.558	1.186	...	H2-1
120	M140	L2x2x3	.635	0	5	.073	0	y 5	21.904	23.393	.558	1.239	...	H2-1
121	M143	L2x2x3	.421	13...	5	.048	0	y 2	21.904	23.393	.558	1.239	...	H2-1
122	M144	L2x2x3	.167	0	5	.006	0	y 5	6.121	23.393	.558	1.151	...	H2-1
123	M145	L2x2x3	.553	13...	5	.056	0	y 5	21.904	23.393	.558	1.239	...	H2-1
124	M148	L2x2x3	.404	13...	5	.038	13...	y 4	21.904	23.393	.558	1.239	1	H2-1
125	M149	L2x2x3	.083	0	5	.002	0	z 5	6.121	23.393	.558	1.143	...	H2-1
126	M150	L2x2x3	.453	13...	5	.040	0	y 5	21.904	23.393	.558	1.239	...	H2-1
127	M153	L2x2x3	.360	13...	5	.046	13...	y 4	21.904	23.393	.558	1.239	...	H2-1
128	M154	L2x2x3	.069	0	5	.002	0	y 5	6.121	23.393	.558	1.238	...	H2-1
129	M155	L2x2x3	.441	13...	5	.046	0	y 4	21.904	23.393	.558	1.239	...	H2-1
130	M158	L2x2x3	.336	13...	4	.047	13...	y 4	21.904	23.393	.558	1.239	...	H2-1
131	M159	L2x2x3	.075	0	5	.002	0	y 5	6.121	23.393	.558	1.231	...	H2-1
132	M160	L2x2x3	.441	13...	5	.048	0	y 5	21.904	23.393	.558	1.239	...	H2-1
133	M163	L2x2x3	.335	13...	4	.047	13...	y 4	21.904	23.393	.558	1.239	...	H2-1
134	M164	L2x2x3	.060	0	5	.003	0	y 5	6.121	23.393	.558	1.22	...	H2-1
135	M165	L2x2x3	.436	13...	5	.055	0	y 5	21.904	23.393	.558	1.239	...	H2-1
136	M168	L2x2x3	.335	13...	4	.047	13...	y 4	21.904	23.393	.558	1.239	...	H2-1
137	M169	L2x2x3	.053	0	5	.003	0	y 5	6.121	23.393	.558			

Envelope AISC 14th(360-10): LRFD Steel Code Checks (Continued)

Member	Shape	Code Check	Lo...	LC	Shear ...	Lo...	phi*P...	phi*P...	phi*Mn...	phi*Mn...	Eqn		
161	M203	L2x2x3	.271	24	5	.021	0	y 2	19.145	23.393	.558	1.239	... H2-1
162	M204	L2x2x3	.206	24	2	.018	0	y 2	19.145	23.393	.558	1.239	... H2-1
163	M205	L2x2x3	.195	0	4	.018	0	y 4	19.145	23.393	.558	1.239	... H2-1
164	M206	L2x2x3	.189	0	5	.020	0	z 5	19.145	23.393	.558	1.239	... H2-1
165	M207	L2x2x3	.180	0	4	.018	0	y 4	19.145	23.393	.558	1.239	... H2-1
166	M208	L2x2x3	.190	24	4	.018	0	y 4	19.145	23.393	.558	1.239	... H2-1
167	M209	L2x2x3	.196	0	4	.018	0	y 4	19.145	23.393	.558	1.239	... H2-1
168	M210	L2x2x3	.232	24	4	.020	0	y 4	19.145	23.393	.558	1.239	... H2-1
169	M211	L2x2x3	.255	24	4	.023	0	y 4	19.145	23.393	.558	1.239	... H2-1
170	M212	L2x2x3	.294	24	4	.025	0	y 4	19.145	23.393	.558	1.239	... H2-1
171	M213	L2x2x3	.387	24	4	.028	0	y 4	19.145	23.393	.558	1.239	... H2-1
172	M216	L2x2x3	.527	0	2	.039	0	y 2	19.145	23.393	.558	1.239	... H2-1
173	M217	L2x2x3	.344	0	5	.028	0	z 5	19.145	23.393	.558	1.239	... H2-1
174	M218	L2x2x3	.280	0	5	.028	0	z 5	19.145	23.393	.558	1.239	... H2-1
175	M219	L2x2x3	.255	24	5	.028	0	z 5	19.145	23.393	.558	1.239	... H2-1
176	M220	L2x2x3	.269	24	5	.027	0	z 5	19.145	23.393	.558	1.239	... H2-1
177	M221	L2x2x3	.279	24	5	.026	0	z 5	19.145	23.393	.558	1.239	... H2-1
178	M222	L2x2x3	.284	24	5	.024	24	y 2	19.145	23.393	.558	1.239	... H2-1
179	M223	L2x2x3	.287	24	5	.025	0	z 5	19.145	23.393	.558	1.239	... H2-1
180	M224	L2x2x3	.294	24	5	.027	0	z 5	19.145	23.393	.558	1.239	... H2-1
181	M225	L2x2x3	.297	24	5	.028	.5	z 5	19.145	23.393	.558	1.239	... H2-1
182	M226	L2x2x3	.317	24	5	.027	0	z 5	19.145	23.393	.558	1.239	... H2-1
183	M227	L2x2x3	.347	24	5	.032	0	z 5	19.145	23.393	.558	1.239	... H2-1
184	M228	L2x2x3	.385	24	5	.033	0	z 5	19.145	23.393	.558	1.239	... H2-1
185	M229	L2x2x3	.504	24	5	.040	0	z 5	19.145	23.393	.558	1.239	... H2-1
186	M230	L2x2x3	.688	0	5	.026	.502	y 5	19.112	23.393	.558	1.239	... H2-1
187	M231	L2x2x3	.645	0	5	.029	24...	z 5	19.112	23.393	.558	1.239	... H2-1
188	M232	L2x2x3	.623	0	5	.031	0	y 5	19.112	23.393	.558	1.239	... H2-1
189	M233	L2x2x3	.569	0	5	.031	4.5...	y 5	19.112	23.393	.558	1.239	... H2-1
190	M234	L2x2x3	.488	0	5	.027	.251	y 5	19.112	23.393	.558	1.239	... H2-1
191	M235	L2x2x3	.432	0	5	.025	0	y 5	19.112	23.393	.558	1.239	... H2-1
192	M236	L2x2x3	.397	0	5	.024	0	y 5	19.112	23.393	.558	1.239	... H2-1
193	M237	L2x2x3	.373	0	5	.024	2.5...	y 5	19.112	23.393	.558	1.239	... H2-1
194	M238	L2x2x3	.350	0	5	.024	0	y 5	19.112	23.393	.558	1.239	... H2-1
195	M239	L2x2x3	.338	0	5	.024	0	y 5	19.112	23.393	.558	1.239	... H2-1
196	M240	L2x2x3	.316	0	5	.024	0	y 5	19.112	23.393	.558	1.239	... H2-1
197	M241	L2x2x3	.299	0	5	.022	0	y 5	19.112	23.393	.558	1.239	... H2-1
198	M242	L2x2x3	.458	24...	5	.052	.502	y 4	19.112	23.393	.558	1.239	... H2-1
199	M243	L2x2x3	.555	24...	4	.021	.753	z 4	19.112	23.393	.558	1.239	... H2-1
200	M244	L2x2x3	.521	24...	4	.021	0	z 5	19.112	23.393	.558	1.239	... H2-1
201	M245	L2x2x3	.498	0	4	.022	0	z 4	19.112	23.393	.558	1.239	... H2-1
202	M246	L2x2x3	.463	0	4	.023	1.2...	z 4	19.112	23.393	.558	1.239	... H2-1
203	M247	L2x2x3	.418	0	4	.023	24...	z 5	19.112	23.393	.558	1.239	... H2-1
204	M248	L2x2x3	.371	0	4	.024	24...	z 5	19.112	23.393	.558	1.239	... H2-1
205	M249	L2x2x3	.337	0	4	.025	24...	z 5	19.112	23.393	.558	1.239	... H2-1
206	M250	L2x2x3	.309	0	4	.025	24...	z 5	19.112	23.393	.558	1.239	... H2-1
207	M251	L2x2x3	.284	0	4	.024	24...	z 5	19.112	23.393	.558	1.239	... H2-1
208	M252	L2x2x3	.263	0	4	.026	0	y 5	19.112	23.393	.558	1.239	... H2-1
209	M253	L2x2x3	.246	0	4	.026	0	y 5	19.112	23.393	.558	1.239	... H2-1
210	M254	L2x2x3	.334	24...	5	.032	0	y 5	19.112	23.393	.558	1.239	... H2-1
211	M255	L2x2x3	.472	24...	4	.051	0	z 4	19.112	23.393	.558	1.239	... H2-1
212	M256	L2x2x3	.634	0	4	.031	0	z 4	2.981	23.393	.558	1.002	... H2-1
213	M257	L2x2x3	.626	0	4	.031	0	z 5	2.981	23.393	.558	1.01	... H2-1
214	M258	L2x2x3	.626	0	4	.031	0	z 5	2.981	23.393	.558	1.009	... H2-1
215	M259	L2x2x3	.628	0	4	.031	0	z 4	2.981	23.393	.558	.997	... H2-1
216	M260	L2x2x3	.630	0	4	.031	0	z 4	2.981	23.393	.558	.978	... H2-1
217	M261	L2x2x3	.634	91	4	.031	91	z 4	2.981	23.393	.558	.978	... H2-1
218	M262	L2x2x3	.634	91	4	.031	91	z 4	2.981	23.393	.558	.976	... H2-1
219	M263	L2x2x3	.635	91	4	.031	91	z 4	2.981	23.393	.558	.976	... H2-1

Envelope AISC 14th(360-10): LRFD Steel Code Checks (Continued)

Member	Shape	Code Check	Lo...	LC	Shear ...	Lo...	phi*P...	phi*P...	phi*Mn...	phi*Mn...	Eqn		
220	M264	L2x2x3	.636	91	4	.031	91	z 4	2.981	23.393	.558	.976	... H2-1
221	M265	L2x2x3	.638	91	4	.031	91	z 4	2.981	23.393	.558	.976	... H2-1
222	M266	L2x2x3	.636	91	4	.031	91	z 4	2.981	23.393	.558	.975	... H2-1
223	M267	L2x2x3	.637	0	4	.031	0	z 4	2.981	23.393	.558	.974	... H2-1
224	M268	L2x2x3	.674	0	4	.034	0	z 4	2.981	23.393	.558	1.002	... H2-1
225	M269	L2x2x3	.571	0	4	.046	0	z 4	16.667	23.393	.558	1.239	... H2-1
226	M270	L2x2x3	.576	0	4	.046	0	z 4	15.858	23.393	.558	1.239	... H2-1
227	M271	L2x2x3	.543	0	4	.044	0	z 4	15.036	23.393	.558	1.239	... H2-1
228	M272	L2x2x3	.460	0	4	.031	0	z 4	14.208	23.393	.558	1.239	... H2-1
229	M273	L2x2x3	.446	0	4	.030	0	z 4	13.381	23.393	.558	1.239	... H2-1
230	M274	L2x2x3	.427	0	4	.028	0	z 4	12.558	23.393	.558	1.239	... H2-1
231	M275	L2x2x3	.404	0	4	.027	0	z 4	11.746	23.393	.558	1.239	... H2-1
232	M276	L2x2x3	.361	0	4	.024	0	z 4	10.949	23.393	.558	1.239	... H2-1
233	M277	L2x2x3	.342	0	4	.033	48...	z 5	10.171	23.393	.558	1.239	... H2-1
234	M278	L2x2x3	.321	51...	5	.040	51...	z 5	9.417	23.393	.558	1.229	... H2-1
235	M279	L2x2x3	.401	53...	5	.044	53...	z 5	8.669	23.393	.558	1.213	... H2-1
236	M280	L2x2x3	.397	55...	5	.044	55...	z 5	7.992	23.393	.558	1.201	... H2-1
237	M281	L2x2x3	.453	0	5	.039	57...	z 5	7.392	23.393	.558	1.181	... H2-1
238	M282	L2x2x3	.685	0	5	.058	0	y 5	16.667	23.393	.558	1.239	... H2-1
239	M283	L2x2x3	.678	0	5	.056	0	y 5	15.858	23.393	.558	1.239	... H2-1
240	M284	L2x2x3	.617	0	5	.053	0	y 5	15.036	23.393	.558	1.239	... H2-1
241	M285	L2x2x3	.548	0	5	.040	0	y 5	14.208	23.393	.558	1.239	... H2-1
242	M286	L2x2x3	.507	0	5	.039	0	y 5	13.381	23.393	.558	1.239	... H2-1
243	M287	L2x2x3	.464	0	5	.036	0	y 5	12.558	23.393	.558	1.239	... H2-1
244	M288	L2x2x3	.421	0	5	.034	0	y 5	11.746	23.393	.558	1.239	... H2-1
245	M289	L2x2x3	.384	0	5	.032	0	y 5	10.949	23.393	.558	1.239	... H2-1
246	M290	L2x2x3	.406	0	2	.042	0	z 6	10.171	23.393	.558	1.192	... H2-1
247	M291	L2x2x3	.445	0	2	.045	0	z 6	9.417	23.393	.558	1.2	... H2-1
248	M292	L2x2x3	.494	0	2	.047	0	z 2	8.669	23.393	.558	1.2	... H2-1
249	M293	L2x2x3	.536	0	2	.048	0	z 2	7.992	23.393	.558	1.193	... H2-1
250	M294	L2x2x3	.584	0	2	.047	0	z 6	7.392	23.393	.558	1.183	... H2-1
251	M295	HSS12x12x6	.827	0	5	.173	0	z 5	662.3	662.4	223.27	223.27	... H1-1b
252	M296	HSS12x12x6	.000	0	4	.000	0	y 5	661.8	662.4	223.27	223.27	1 H1-1b
253	M297	HSS12x12x6	.428	0	5	.177	0	z 5	661.4	662.4	223.27	223.27	... H1-1b
254	M298	HSS12x12x6	.072	0	5	.041	0	y 2	661.7	662.4	223.27	223.27	... H1-1b
255	M299	HSS12x12x6	.041	0	5	.043	0	y 5	662.35	662.4	223.27	223.27	... H1-1b
256	M300	HSS12x12x6	.628	0	2	.180	0	y 5	662.3	662.4	223.27	223.27	... H1-1b
257	M301	HSS12x12x6	.000	0	4	.000	0	y 5	661.8	662.4	223.27	223.27	1 H

Envelope AISC 14th(360-10): LRFD Steel Code Checks (Continued)

Member	Shape	Code Check	Lo...	LC	Shear ...	Lo...	phi*P...	phi*P...	phi*Mn...	phi*Mn...	Eqn		
279	M325	HSS12x12x6	.409	0	2	.180	0	y 5	661.2...	662.4	223.27	223.27	... H1-1b
280	M326	HSS12x12x6	.231	0	2	.181	0	y 5	661.2...	662.4	223.27	223.27	... H1-1b
281	M327	HSS12x12x6	.247	24	2	.182	0	y 5	661.2...	662.4	223.27	223.27	... H1-1b
282	M328	HSS12x12x6	.420	24	2	.189	0	y 5	661.2...	662.4	223.27	223.27	... H1-1b
283	M329	HSS12x12x6	.534	0	5	.173	0	y 2	661.2...	662.4	223.27	223.27	... H1-1b
284	M330	HSS12x12x6	.286	0	5	.173	0	y 2	661.2...	662.4	223.27	223.27	... H1-1b
285	M331	HSS12x12x6	.363	24	5	.173	0	y 2	661.2...	662.4	223.27	223.27	... H1-1b
286	M332	HSS12x12x6	.619	24	5	.177	0	y 2	661.2...	662.4	223.27	223.27	... H1-1b
287	M343	L2x2x3	.471	13...	5	.064	0	y 5	21.904	23.393	.558	1.239	... H2-1
288	M344	L2x2x3	.453	0	5	.022	0	z 5	6.121	23.393	.558	1.196	... H2-1
289	M345	L2x2x3	.585	0	5	.075	0	z 5	21.904	23.393	.558	1.239	... H2-1
290	M346	L2x2x3	.556	13...	4	.080	13...	y 4	21.904	23.393	.558	1.239	... H2-1
291	M347	L2x2x3	.420	0	5	.019	0	y 5	6.121	23.393	.558	1.197	... H2-1
292	M348	L2x2x3	.697	0	5	.094	0	y 5	21.904	23.393	.558	1.239	... H2-1
293	M349	L2x2x3	.560	13...	4	.074	13...	y 4	21.904	23.393	.558	1.239	... H2-1
294	M350	L2x2x3	.372	0	5	.017	0	y 5	6.121	23.393	.558	1.197	... H2-1
295	M351	L2x2x3	.576	0	5	.076	0	y 5	21.904	23.393	.558	1.239	... H2-1
296	M352	L2x2x3	.651	13...	5	.075	13...	y 5	21.904	23.393	.558	1.239	... H2-1
297	M353	L2x2x3	.244	0	5	.011	0	y 5	6.121	23.393	.558	1.197	... H2-1
298	M354	L2x2x3	.482	0	4	.061	0	y 4	21.904	23.393	.558	1.239	... H2-1
299	M355	L2x2x3	.856	13...	5	.085	13...	y 5	21.904	23.393	.558	1.239	... H2-1
300	M356	L2x2x3	.041	0	5	.002	0	y 5	6.121	23.393	.558	1.203	... H2-1
301	M357	L2x2x3	.588	0	2	.066	0	y 2	21.904	23.393	.558	1.239	... H2-1
302	M358	L2x2x3	.306	16	4	.056	0	z 4	21.399	23.393	.558	1.239	... H2-1
303	M359	L2x2x3	.396	16	5	.058	0	y 5	21.399	23.393	.558	1.239	... H2-1
304	M360	L2x2x3	.211	0	4	.023	24...	z 5	19.138	23.393	.558	1.239	... H2-1
305	M361	L2x2x3	.292	0	5	.022	0	y 4	19.138	23.393	.558	1.239	... H2-1
306	M362	L2x2x3	.705	0	5	.033	0	y 5	2.981	23.393	.558	1.094	... H2-1
307	M363	L2x2x3	.354	0	5	.019	0	z 5	2.981	23.393	.558	1.088	... H2-1
308	M364	L2x2x3	.207	20	4	.028	0	y 4	20.354	23.393	.558	1.239	... H2-1
309	M365	L2x2x3	.219	0	5	.036	0	z 5	20.354	23.393	.558	1.239	... H2-1
310	M366	L2x2x3	.285	24	2	.027	24	y 2	19.145	23.393	.558	1.239	... H2-1
311	M367	L2x2x3	.218	0	5	.023	0	z 4	19.145	23.393	.558	1.239	... H2-1
312	M368	L2x2x3	.233	24	4	.028	0	y 5	19.145	23.393	.558	1.239	... H2-1
313	M369	L2x2x3	.259	24	5	.030	0	y 5	19.145	23.393	.558	1.239	... H2-1
314	M370	L2x2x3	.382	0	5	.034	0	z 5	19.145	23.393	.558	1.239	... H2-1
315	M371	L2x2x3	.216	0	4	.023	0	y 4	19.145	23.393	.558	1.239	... H2-1
316	M372	L2x2x3	.279	24	5	.026	0	y 4	19.145	23.393	.558	1.239	... H2-1
317	M373	L2x2x3	.322	24	5	.023	0	y 5	19.145	23.393	.558	1.239	... H2-1
318	M374	L2x2x3	.222	0	4	.024	.25	z 4	19.138	23.393	.558	1.239	... H2-1
319	M375	L2x2x3	.223	24...	4	.026	0	y 4	19.138	23.393	.558	1.239	... H2-1
320	M376	L2x2x3	.349	24...	4	.038	0	z 4	19.138	23.393	.558	1.239	... H2-1
321	M377	L2x2x3	.341	0	5	.030	0	y 5	19.138	23.393	.558	1.239	... H2-1
322	M378	L2x2x3	.298	0	5	.032	.751	y 5	19.138	23.393	.558	1.239	... H2-1
323	M379	L2x2x3	.464	24...	5	.050	1.5...	y 5	19.138	23.393	.558	1.239	... H2-1
324	M380	L2x2x3	.517	0	4	.062	0	y 4	21.155	23.393	.558	1.239	... H2-1
325	M381	L2x2x3	.545	18	4	.063	0	y 4	20.899	23.393	.558	1.239	... H2-1
326	M382	L2x2x3	.426	19	4	.050	0	y 4	20.632	23.393	.558	1.239	... H2-1
327	M383	L2x2x3	.426	19	4	.050	0	z 4	20.632	23.393	.558	1.239	... H2-1
328	M384	L2x2x3	.553	18	5	.063	0	z 4	20.899	23.393	.558	1.239	... H2-1
329	M385	L2x2x3	.553	17	5	.062	0	z 4	21.155	23.393	.558	1.239	... H2-1
330	M386	L2x2x3	.742	0	5	.036	0	z 5	2.981	23.393	.558	1.112	... H2-1
331	M387	L2x2x3	.722	0	5	.035	0	z 5	2.981	23.393	.558	1.113	... H2-1
332	M388	L2x2x3	.672	0	5	.034	0	z 5	2.981	23.393	.558	1.109	... H2-1
333	M389	L2x2x3	.626	13...	5	.088	13...	z 5	21.904	23.393	.558	1.239	... H2-1
334	M390	L2x2x3	.037	0	5	.002	0	z 5	6.121	23.393	.558	1.2	... H2-1
335	M391	L2x2x3	.670	0	2	.072	0	z 2	21.904	23.393	.558	1.239	... H2-1
336	M394	L2x2x3	.504	0	5	.027	60	y 5	6.856	23.393	.558	1.147	... H2-1
337	M395	L2x2x3	.355	91	5	.016	0	y 5	2.981	23.393	.558	1.124	... H2-1

Envelope AISC 14th(360-10): LRFD Steel Code Checks (Continued)

Member	Shape	Code Check	Lo...	LC	Shear ...	Lo...	phi*P...	phi*P...	phi*Mn...	phi*Mn...	Eqn		
338	M396	L2x2x3	.383	0	2	.032	0	y 6	6.856	23.393	.558	1.136	... H2-1
339	M397	HSS12x12x6	.641	2	5	.178	0	y 2	662.3...	662.4	223.27	223.27	... H1-1b
340	M398	HSS12x12x6	.433	2	2	.186	0	y 5	662.3...	662.4	223.27	223.27	... H1-1b
341	M399	HSS12x12x6	.255	0	5	.177	0	z 5	661.2...	662.4	223.27	223.27	... H1-1b
342	M400	HSS12x12x6	.087	0	5	.179	0	z 5	662.3...	662.4	223.27	223.27	... H1-1b
343	M401	HSS12x12x6	.168	0	2	.113	0	y 2	661.2...	662.4	223.27	223.27	... H1-1b
344	M402	HSS12x12x6	.065	0	5	.116	0	y 2	662.3...	662.4	223.27	223.27	... H1-1b
345	M403	HSS12x12x6	.060	0	5	.042	0	y 2	661.2...	662.4	223.27	223.27	... H1-1b
346	M404	HSS12x12x6	.052	0	2	.044	0	y 5	661.2...	662.4	223.27	223.27	... H1-1b
347	M405	HSS12x12x6	.049	0	5	.043	0	y 2	661.2...	662.4	223.27	223.27	... H1-1b
348	M406	HSS12x12x6	.048	0	5	.044	0	z 2	661.6...	662.4	223.27	223.27	... H1-1b
349	M407	HSS12x12x6	.041	0	2	.045	0	y 5	661.2...	662.4	223.27	223.27	... H1-1b
350	M408	HSS12x12x6	.031	0	2	.046	0	y 5	661.6...	662.4	223.27	223.27	... H1-1b
351	M409	HSS12x12x6	.036	0	5	.043	0	y 5	661.2...	662.4	223.27	223.27	... H1-1b
352	M410	HSS12x12x6	.032	0	2	.043	0	y 2	661.2...	662.4	223.27	223.27	... H1-1b
353	M411	HSS12x12x6	.029	24	5	.044	0	z 5	661.2...	662.4	223.27	223.27	... H1-1b
354	M412	HSS12x12x6	.052	24	5	.045	0	z 5	661.2...	662.4	223.27	223.27	... H1-1b
355	M413	HSS12x12x6	.025	24	2	.043	0	y 2	661.2...	662.4	223.27	223.27	... H1-1b
356	M414	HSS12x12x6	.043	24	2	.044	0	z 2	661.2...	662.4	223.27	223.27	... H1-1b
357	M415	HSS12x12x6	.060	8	5	.045	0	y 2	662.2...	662.4	223.27	223.27	... H1-1b
358	M416	HSS12x12x6	.049	8	2	.047	0	z 5	662.2...	662.4	223.27	223.27	... H1-1b
359	M417	L2x2x3	.420	0	2	.021	13...	z 4	21.904	23.393	.558	1.239	... H2-1
360	M418	L2x2x3	.190	63.5	2	.011	0	z 5	6.121	23.393	.558	1.195	... H2-1
361	M419	L2x2x3	.545	13...	5	.030	0	z 2	21.904	23.393	.558	1.239	... H2-1
362	M422	L2x2x3	.658	13...	5	.076	0	z 5	21.904	23.393	.558	1.239	... H2-1
363	M423	L2x2x3	.267	0	5	.015	0	z 5	6.121	23.393	.558	1.194	... H2-1
364	M424	L2x2x3	.649	13...	5	.057	0	z 5	21.904	23.393	.558	1.239	... H2-1
365	M427	L2x2x3	.829	13...	5	.098	0	z 5	21.904	23.393	.558	1.239	... H2-1
366	M428	L2x2x3	.290	0	5	.015	0	z 5	6.121	23.393	.558	1.192	... H2-1
367	M429	L2x2x3	.670	13...	5	.074	0	z 5	21.904	23.393	.558	1.239	... H2-1
368	M432	L2x2x3	.718	13...	2	.083	0	z 5	21.904	23.393	.558	1.239	... H2-1
369	M433	L2x2x3	.259	0	5	.012	0	z 5	6.121	23.393	.558	1.186	... H2-1
370	M434	L2x2x3	.635	0	5	.073	0	z 5	21.904	23.393	.558	1.239	... H2-1
371	M437	L2x2x3	.421	13...	5	.048	0	z 2	21.904	23.393	.558	1.239	... H2-1
372	M438	L2x2x3	.167	0	5	.006	0	z 5	6.121	23.393	.558	1.151	... H2-1
373	M439	L2x2x3	.553	13...	5	.056	0	z 5	21.904	23.393	.558	1.239	... H2-1
374	M442	L2x2x3	.404	13...	5	.038	13...	z 4	21.904	23.393	.558	1.239</	

Envelope AISC 14th(360-10): LRFD Steel Code Checks (Continued)

Member	Shape	Code Check	Lo...	LC	Shear ...	Lo...	phi*P...	phi*P...	phi*Mn...	phi*Mn...	Eqn				
397	M479	L2x2x3	.519	0	5	.075	0	z	5	21.904	23.393	.558	1.239	...	H2-1
398	M482	L2x2x3	.492	13...	4	.075	0	z	4	21.904	23.393	.558	1.239	...	H2-1
399	M483	L2x2x3	.208	63.5	4	.019	63.5	y	4	6.121	23.393	.558	1.204	...	H2-1
400	M484	L2x2x3	.735	0	5	.097	0	z	5	21.904	23.393	.558	1.239	...	H2-1
401	M487	L2x2x3	.657	0	4	.038	0	z	4	21.904	23.393	.558	1.239	...	H2-1
402	M488	L2x2x3	.511	30...	4	.032	0	z	4	6.121	23.393	.558	1.032	...	H2-1
403	M489	L2x2x3	.627	13...	4	.033	13...	z	4	21.904	23.393	.558	1.239	...	H2-1
404	M490	L2x2x3	.389	0	4	.049	0	z	4	17.459	23.393	.558	1.239	...	H2-1
405	M491	L2x2x3	.540	0	5	.049	0	y	5	17.459	23.393	.558	1.239	...	H2-1
406	M492	L2x2x3	.658	0	5	.027	.251	z	5	19.112	23.393	.558	1.239	...	H2-1
407	M493	L2x2x3	.568	24...	4	.026	0	y	4	19.112	23.393	.558	1.239	...	H2-1
408	M494	L2x2x3	.542	0	5	.036	0	y	5	19.145	23.393	.558	1.239	...	H2-1
409	M495	L2x2x3	.344	0	2	.017	0	z	2	19.145	23.393	.558	1.239	...	H2-1
410	M496	L2x2x3	.269	0	5	.021	0	z	2	19.145	23.393	.558	1.239	...	H2-1
411	M497	L2x2x3	.271	24	5	.021	0	z	2	19.145	23.393	.558	1.239	...	H2-1
412	M498	L2x2x3	.206	24	2	.018	0	z	2	19.145	23.393	.558	1.239	...	H2-1
413	M499	L2x2x3	.195	0	4	.018	0	z	4	19.145	23.393	.558	1.239	...	H2-1
414	M500	L2x2x3	.189	0	5	.020	0	y	5	19.145	23.393	.558	1.239	...	H2-1
415	M501	L2x2x3	.180	0	4	.018	0	z	4	19.145	23.393	.558	1.239	...	H2-1
416	M502	L2x2x3	.190	24	4	.018	0	z	4	19.145	23.393	.558	1.239	...	H2-1
417	M503	L2x2x3	.196	0	4	.018	0	z	4	19.145	23.393	.558	1.239	...	H2-1
418	M504	L2x2x3	.232	24	4	.020	0	z	4	19.145	23.393	.558	1.239	...	H2-1
419	M505	L2x2x3	.256	24	4	.023	0	z	4	19.145	23.393	.558	1.239	...	H2-1
420	M506	L2x2x3	.292	24	4	.025	0	z	4	19.145	23.393	.558	1.239	...	H2-1
421	M507	L2x2x3	.385	24	4	.028	0	z	4	19.145	23.393	.558	1.239	...	H2-1
422	M510	L2x2x3	.527	0	2	.039	0	z	2	19.145	23.393	.558	1.239	...	H2-1
423	M511	L2x2x3	.344	0	5	.028	0	y	5	19.145	23.393	.558	1.239	...	H2-1
424	M512	L2x2x3	.280	0	5	.028	0	y	5	19.145	23.393	.558	1.239	...	H2-1
425	M513	L2x2x3	.254	24	5	.028	0	y	5	19.145	23.393	.558	1.239	...	H2-1
426	M514	L2x2x3	.269	24	5	.027	0	y	5	19.145	23.393	.558	1.239	...	H2-1
427	M515	L2x2x3	.279	24	5	.026	0	y	5	19.145	23.393	.558	1.239	...	H2-1
428	M516	L2x2x3	.284	24	5	.024	24	z	2	19.145	23.393	.558	1.239	...	H2-1
429	M517	L2x2x3	.287	24	5	.025	0	y	5	19.145	23.393	.558	1.239	...	H2-1
430	M518	L2x2x3	.294	24	5	.027	0	y	5	19.145	23.393	.558	1.239	...	H2-1
431	M519	L2x2x3	.297	24	5	.028	0	y	5	19.145	23.393	.558	1.239	...	H2-1
432	M520	L2x2x3	.317	24	5	.027	1.25	y	5	19.145	23.393	.558	1.239	...	H2-1
433	M521	L2x2x3	.346	24	5	.032	0	y	5	19.145	23.393	.558	1.239	...	H2-1
434	M522	L2x2x3	.386	24	5	.033	0	y	5	19.145	23.393	.558	1.239	...	H2-1
435	M523	L2x2x3	.506	24	5	.040	0	y	5	19.145	23.393	.558	1.239	...	H2-1
436	M524	L2x2x3	.688	0	5	.026	1.5...	z	5	19.112	23.393	.558	1.239	...	H2-1
437	M525	L2x2x3	.645	0	5	.029	24...	y	5	19.112	23.393	.558	1.239	...	H2-1
438	M526	L2x2x3	.624	0	5	.031	0	z	5	19.112	23.393	.558	1.239	...	H2-1
439	M527	L2x2x3	.569	0	5	.031	3.0...	z	5	19.112	23.393	.558	1.239	...	H2-1
440	M528	L2x2x3	.488	0	5	.027	0	z	5	19.112	23.393	.558	1.239	...	H2-1
441	M529	L2x2x3	.432	0	5	.025	0	z	5	19.112	23.393	.558	1.239	...	H2-1
442	M530	L2x2x3	.398	0	5	.024	0	z	5	19.112	23.393	.558	1.239	...	H2-1
443	M531	L2x2x3	.373	0	5	.024	0	z	5	19.112	23.393	.558	1.239	...	H2-1
444	M532	L2x2x3	.350	0	5	.024	.251	z	5	19.112	23.393	.558	1.239	...	H2-1
445	M533	L2x2x3	.339	0	5	.024	.753	z	5	19.112	23.393	.558	1.239	...	H2-1
446	M534	L2x2x3	.317	0	5	.024	0	z	5	19.112	23.393	.558	1.239	...	H2-1
447	M535	L2x2x3	.298	0	5	.022	0	z	5	19.112	23.393	.558	1.239	...	H2-1
448	M536	L2x2x3	.479	24...	5	.051	0	z	4	19.112	23.393	.558	1.239	...	H2-1
449	M537	L2x2x3	.554	24...	4	.021	1.5...	y	4	19.112	23.393	.558	1.239	...	H2-1
450	M538	L2x2x3	.520	24...	4	.021	0	y	5	19.112	23.393	.558	1.239	...	H2-1
451	M539	L2x2x3	.498	0	4	.022	0	y	4	19.112	23.393	.558	1.239	...	H2-1
452	M540	L2x2x3	.463	0	4	.023	0	y	4	19.112	23.393	.558	1.239	...	H2-1
453	M541	L2x2x3	.417	0	4	.023	24...	y	5	19.112	23.393	.558	1.239	...	H2-1
454	M542	L2x2x3	.370	0	4	.024	24...	y	5	19.112	23.393	.558	1.239	...	H2-1
455	M543	L2x2x3	.336	0	4	.025	24...	y	5	19.112	23.393	.558	1.239	...	H2-1

Envelope AISC 14th(360-10): LRFD Steel Code Checks (Continued)

Member	Shape	Code Check	Lo...	LC	Shear ...	Lo...	phi*P...	phi*P...	phi*Mn...	phi*Mn...	Eqn				
456	M544	L2x2x3	.309	0	4	.025	24...	y	5	19.112	23.393	.558	1.239	...	H2-1
457	M545	L2x2x3	.284	0	4	.024	24...	y	5	19.112	23.393	.558	1.239	...	H2-1
458	M546	L2x2x3	.262	0	4	.026	0	z	5	19.112	23.393	.558	1.239	...	H2-1
459	M547	L2x2x3	.246	0	4	.026	0	z	5	19.112	23.393	.558	1.239	...	H2-1
460	M548	L2x2x3	.328	24...	5	.031	0	z	5	19.112	23.393	.558	1.239	...	H2-1
461	M549	L2x2x3	.447	24...	4	.052	1.0...	y	4	19.112	23.393	.558	1.239	...	H2-1
462	M550	L2x2x3	.634	0	4	.031	0	y	4	2.981	23.393	.558	1.002	...	H2-1
463	M551	L2x2x3	.626	0	4	.031	0	y	5	2.981	23.393	.558	1.01	...	H2-1
464	M552	L2x2x3	.626	0	4	.031	0	y	5	2.981	23.393	.558	1.009	...	H2-1
465	M553	L2x2x3	.628	0	4	.031	0	y	4	2.981	23.393	.558	.997	...	H2-1
466	M554	L2x2x3	.630	91	4	.031	91	y	4	2.981	23.393	.558	.978	...	H2-1
467	M555	L2x2x3	.634	91	4	.031	91	y	4	2.981	23.393	.558	.978	...	H2-1
468	M556	L2x2x3	.634	91	4	.031	91	y	4	2.981	23.393	.558	.976	...	H2-1
469	M557	L2x2x3	.635	91	4	.031	91	y	4	2.981	23.393	.558	.976	...	H2-1
470	M558	L2x2x3	.636	91	4	.031	91	y	4	2.981	23.393	.558	.976	...	H2-1
471	M559	L2x2x3	.638	91	4	.031	91	y	4	2.981	23.393	.558	.976	...	H2-1
472	M560	L2x2x3	.636	91	4	.031	0	y	4	2.981	23.393	.558	.975	...	H2-1
473	M561	L2x2x3	.637	91	4	.031	91	y	4	2.981	23.393	.558	.974	...	H2-1
474	M562	L2x2x3	.674	91	4	.034	91	y	4	2.981	23.393	.558	1.002	...	H2-1
475	M563	L2x2x3	.569	0	4	.046	0	y	4	16.667	23.393	.558	1.239	...	H2-1
476	M564	L2x2x3	.576	0	4	.046	0	y	4	15.858	23.393	.558	1.239	...	H2-1
477	M565	L2x2x3	.544	0	4	.044	0	y	4	15.036	23.393	.558	1.239	...	H2-1
478	M566	L2x2x3	.461	0	4	.031	0	y	4	14.208	23.393	.558	1.239	...	H2-1
479	M567	L2x2x3	.447	0	4	.030	0	y	4	13.381	23.393	.558	1.239	...	H2-1
480	M568	L2x2x3	.428	0	4	.028	0	y	4	12.558	23.393	.558	1.239	...	H2-1
481	M569	L2x2x3	.405	0	4	.027	0	y	4	11.746	23.393	.558	1.239	...	H2-1
482	M570	L2x2x3	.362	0	4	.024	0	y	4	10.949	23.393	.558	1.239	...	H2-1
483	M571	L2x2x3	.342	0	4	.033	48...	y	5	10.171	23.393	.558	1.239	...	H2-1
484	M572	L2x2x3	.321	51...	5	.040	51...	y	5	9.417	23.393	.558	1.229	...	H2-1
485	M573	L2x2x3	.401	53...	5	.044	53...	y	5	8.669	23.393	.558	1.213	...	H2-1
486	M574	L2x2x3	.397	55...	5	.043	55...	y	5	7.992	23.393	.558	1.201	...	H2-1
487	M575	L2x2x3	.453	0	5	.039	57...	y	5	7.392	23.393	.558	1.181	...	H2-1
488	M576	L2x2x3	.687	0	5	.058	0	z	5	16.667	23.393	.558	1.239	...	H2-

Envelope AISC 14th(360-10): LRFD Steel Code Checks (Continued)

Member	Shape	Code Check	Lo...	LC	Shear ...	Lo...	phi*P...	phi*P...	phi*Mn...	phi*Mn...	Eqn		
515	M606	HSS6x6x4	.094	0	5	.027	62...	y 5	206.8...	216.9...	38.64	38.64	H1-1b
516	M607	HSS6x6x4	.120	0	5	.025	61...	y 5	207.0...	216.9...	38.64	38.64	H1-1b
517	M608	HSS6x6x4	.131	14...	5	.014	0	y 2	207.0...	216.9...	38.64	38.64	H1-1b
518	M608A	HSS6x6x4	.259	0	5	.010	61...	y 5	207.1...	216.9...	38.64	38.64	H1-1a
519	M611	HSS6x6x4	.068	0	4	.034	0	z 5	205.4...	216.9...	38.64	38.64	H1-...
520	M612	HSS6x6x4	.040	0	4	.032	65...	z 5	205.8...	216.9...	38.64	38.64	H1-1b
521	M613	HSS6x6x4	.072	0	5	.028	0	y 5	206.1...	216.9...	38.64	38.64	H1-...
522	M614	HSS6x6x4	.059	0	2	.032	0	y 5	206.4...	216.9...	38.64	38.64	H1-...
523	M615	HSS6x6x4	.096	0	2	.031	0	y 5	206.6...	216.9...	38.64	38.64	H1-...
524	M616	HSS6x6x4	.102	0	2	.029	0	y 5	206.8...	216.9...	38.64	38.64	H1-...
525	M617	HSS6x6x4	.138	0	2	.024	0	y 5	207.0...	216.9...	38.64	38.64	H1-...
526	M618	HSS6x6x4	.150	0	2	.015	0	y 5	207.0...	216.9...	38.64	38.64	H1-...
527	M619	HSS6x6x4	.179	0	2	.009	0	y 5	207.1...	216.9...	38.64	38.64	H1-...
528	M620	HSS6x6x4	.068	0	4	.034	0	z 5	205.4...	216.9...	38.64	38.64	H1-...
529	M621	HSS6x6x4	.040	0	4	.032	65...	z 5	205.8...	216.9...	38.64	38.64	H1-1b
530	M622	HSS6x6x4	.072	0	5	.028	0	y 5	206.1...	216.9...	38.64	38.64	H1-...
531	M623	HSS6x6x4	.059	0	2	.032	0	y 5	206.4...	216.9...	38.64	38.64	H1-...
532	M624	HSS6x6x4	.096	0	2	.031	0	y 5	206.6...	216.9...	38.64	38.64	H1-...
533	M625	HSS6x6x4	.102	0	2	.029	0	y 5	206.8...	216.9...	38.64	38.64	H1-...
534	M626	HSS6x6x4	.138	0	2	.024	0	y 5	207.0...	216.9...	38.64	38.64	H1-...
535	M627	HSS6x6x4	.150	0	2	.015	0	y 5	207.0...	216.9...	38.64	38.64	H1-...
536	M628	HSS6x6x4	.179	0	2	.009	0	y 5	207.1...	216.9...	38.64	38.64	H1-...
537	M631	HSS4x4x3	.167	0	5	.048	0	y 5	102.1...	106.8...	12.662	12.662	H1-1b
538	M632	HSS4x4x3	.124	40	5	.044	0	y 5	102.1...	106.8...	12.662	12.662	H1-1b
539	M633	HSS4x4x3	.076	0	2	.035	0	y 5	102.1...	106.8...	12.662	12.662	H1-1b
540	M634	HSS4x4x3	.042	40	5	.033	0	z 5	102.1...	106.8...	12.662	12.662	H1-1b
541	M635	HSS4x4x3	.057	0	2	.032	0	z 2	102.1...	106.8...	12.662	12.662	H1-1b
542	M636	HSS4x4x3	.077	40	5	.034	40	y 5	102.1...	106.8...	12.662	12.662	H1-1b
543	M637	HSS4x4x3	.084	0	5	.034	40	y 5	102.1...	106.8...	12.662	12.662	H1-1b
544	M638	HSS4x4x3	.079	40	2	.028	0	y 2	102.1...	106.8...	12.662	12.662	H1-1b
545	M639	HSS4x4x3	.052	40	5	.017	40	y 5	102.1...	106.8...	12.662	12.662	H1-1b
546	M640	HSS4x4x3	.027	0	5	.006	0	y 5	102.1...	106.8...	12.662	12.662	H1-1b
547	M641	HSS4x4x3	.052	40	5	.017	40	y 5	102.1...	106.8...	12.662	12.662	H1-1b
548	M642	HSS4x4x3	.079	40	2	.028	0	y 2	102.1...	106.8...	12.662	12.662	H1-1b
549	M643	HSS4x4x3	.084	0	5	.034	40	y 5	102.1...	106.8...	12.662	12.662	H1-1b
550	M644	HSS4x4x3	.077	40	5	.034	40	y 5	102.1...	106.8...	12.662	12.662	H1-1b
551	M645	HSS4x4x3	.057	0	2	.032	0	z 2	102.1...	106.8...	12.662	12.662	H1-1b
552	M646	HSS4x4x3	.042	40	5	.033	0	z 5	102.1...	106.8...	12.662	12.662	H1-1b
553	M647	HSS4x4x3	.076	0	2	.035	0	y 5	102.1...	106.8...	12.662	12.662	H1-1b
554	M648	HSS4x4x3	.124	40	5	.044	0	y 5	102.1...	106.8...	12.662	12.662	H1-1b
555	M649	HSS4x4x3	.167	0	5	.048	0	y 5	102.1...	106.8...	12.662	12.662	H1-1b
556	M650	HSS8x8x4	.104	61.2	2	.036	0	z 2	286.5...	293.94	66.288	66.288	H1-1b
557	M651	HSS8x8x4	.125	61.2	2	.047	0	y 2	286.5...	293.94	66.288	66.288	H1-1b
558	M652	HSS8x8x4	.164	0	5	.050	0	y 2	286.5...	293.94	66.288	66.288	H1-...
559	M653	HSS8x8x4	.197	0	5	.052	0	y 2	286.5...	293.94	66.288	66.288	H1-...
560	M654	HSS8x8x4	.322	61.2	2	.048	0	y 2	286.5...	293.94	66.288	66.288	H1-1a
561	M655	HSS8x8x4	.316	61.2	2	.045	0	y 2	286.5...	293.94	66.288	66.288	H1-1a
562	M656	HSS8x8x4	.335	61.2	5	.033	0	y 2	286.5...	293.94	66.288	66.288	H1-1a
563	M657	HSS8x8x4	.325	0	5	.021	0	y 2	286.5...	293.94	66.288	66.288	H1-1a
564	M658	HSS8x8x4	.346	61.2	5	.008	0	y 5	286.5...	293.94	66.288	66.288	H1-1a
565	M659	HSS8x8x4	.346	0	5	.008	61.2	y 5	286.5...	293.94	66.288	66.288	H1-1a
566	M660	HSS8x8x4	.325	61.2	5	.021	0	y 2	286.5...	293.94	66.288	66.288	H1-1a
567	M661	HSS8x8x4	.335	0	5	.033	0	y 2	286.5...	293.94	66.288	66.288	H1-1a
568	M662	HSS8x8x4	.316	0	2	.045	0	y 2	286.5...	293.94	66.288	66.288	H1-1a
569	M663	HSS8x8x4	.322	0	2	.048	0	y 2	286.5...	293.94	66.288	66.288	H1-1a
570	M664	HSS8x8x4	.197	0	5	.052	0	y 2	286.5...	293.94	66.288	66.288	H1-...
571	M665	HSS8x8x4	.164	0	5	.050	0	y 2	286.5...	293.94	66.288	66.288	H1-...
572	M666	HSS8x8x4	.125	0	2	.047	0	y 2	286.5...	293.94	66.288	66.288	H1-1b
573	M667	HSS8x8x4	.104	0	2	.036	0	z 2	286.5...	293.94	66.288	66.288	H1-1b

Envelope AISC 14th(360-10): LRFD Steel Code Checks (Continued)

Member	Shape	Code Check	Lo...	LC	Shear ...	Lo...	phi*P...	phi*P...	phi*Mn...	phi*Mn...	Eqn		
574	M669	HSS8x8x4	.109	61.2	5	.043	0	y 5	286.5...	293.94	66.288	66.288	H1-1b
575	M670	HSS8x8x4	.156	61.2	5	.051	0	y 5	286.5...	293.94	66.288	66.288	H1-1b
576	M671	HSS8x8x4	.144	61.2	5	.060	0	y 5	286.5...	293.94	66.288	66.288	H1-1b
577	M672	HSS8x8x4	.311	61.2	5	.059	0	y 5	286.5...	293.94	66.288	66.288	H1-1a
578	M673	HSS8x8x4	.314	61.2	6	.060	0	y 5	286.5...	293.94	66.288	66.288	H1-1a
579	M674	HSS8x8x4	.340	61.2	5	.052	0	y 5	286.5...	293.94	66.288	66.288	H1-1a
580	M675	HSS8x8x4	.328	61.2	5	.044	0	y 5	286.5...	293.94	66.288	66.288	H1-1a
581	M676	HSS8x8x4	.312	61.2	2	.025	0	y 5	286.5...	293.94	66.288	66.288	H1-1a
582	M677	HSS8x8x4	.288	61.2	2	.007	0	z 5	286.5...	293.94	66.288	66.288	H1-1a
583	M678	HSS8x8x4	.288	0	2	.007	61.2	z 5	286.5...	293.94	66.288	66.288	H1-1a
584	M679	HSS8x8x4	.312	0	2	.025	61.2	y 5	286.5...	293.94	66.288	66.288	H1-1a
585	M680	HSS8x8x4	.328	0	5	.044	61.2	y 5	286.5...	293.94	66.288	66.288	H1-1a
586	M681	HSS8x8x4	.340	0	5	.052	61.2	y 5	286.5...	293.94	66.288	66.288	H1-1a
587	M682	HSS8x8x4	.314	0	6	.060	61.2	y 5	286.5...	293.94	66.288	66.288	H1-1a
588	M683	HSS8x8x4	.311	0	5	.059	61.2	y 5	286.5...	293.94	66.288	66.288	H1-1a
589	M684	HSS8x8x4	.144	0	5	.060	61.2	y 5	286.5...	293.94	66.288	66.288	H1-1b
590	M685	HSS8x8x4	.156	0	5	.051	61.2	y 5	286.5...	293.94	66.288	66.288	H1-1b
591	M686	HSS8x8x4	.109	0	5	.043	61.2	y 5	286.5...	293.94	66.288	66.288	H1-1b
592	M688	HSS6x6x4	.122	0	5	.044	0	z 2	205.9...	216.9...	38.64	38.64	H1-1b
593	M689	HSS6x6x4	.100	64...	5	.037	0	y 5	206.2...	216.9...	38.64	38.64	H1-1b
594	M690	HSS6x6x4	.100	63...	5	.037	0	y 5	206.4...	216.9...	38.64	38.64	H1-1b
595	M691	HSS6x6x4	.125	62...	5	.045	0	y 5	206.6...	216.9...	38.64	38.64	H1-1b
596	M692	HSS6x6x4	.136	62...	5	.046	0	y 5	206.8...	216.9...	38.64	38.64	H1-1b
597	M693	HSS6x6x4	.142	61...	5	.041	0	y 5	206.9...	216.9...	38.64	38.64	H1-1b
598	M694	HSS6x6x4	.131	61...	5	.034	0	y 5	207.0...	216.9...	38.64	38.64	H1-1b
599	M695	HSS6x6x4	.108	61...	5	.018	0	y 5	207.1...	216.9...	38.64	38.64	H1-1b
600	M696	HSS6x6x4	.086	61...	2	.007	61...	y 5	207.1...	216.9...	38.64	38.64	H1-1b
601	M697	HSS6x6x4	.122	0	5	.044	0	z 2	205.9...	216.9...	38.64	38.64	H1-1b
602	M698	HSS6x6x4	.100	64...	5	.037	0	y 5	206.2...	216.9...	38.64	38.64	H1-1b
603	M699	HSS6x6x4	.100	63...	5	.037	0	y 5	206.4...	216.9...	38.64	38.64	H1-1b
604	M700	HSS6x6x4	.125	62...	5	.045	0	y 5	206.6...	216.9...	38.64	38.64	H1-1b
605	M701	HSS6x6x4	.136	62...	5	.046	0	y 5	206.8...	216.9...	38.64	38.64	H1-1b
606	M702	HSS6x6x4	.142	61...	5	.041	0	y 5	206.9...	216.9...	38.64	38.64	H1-1b
607	M703	HSS6x6x4	.131	61...	5	.034	0	y 5	207.0...	216.9...	38.64	38.64	H1-1b
608	M704	HSS6x6x4	.108	61...	5	.018	0	y 5	207.1...	216.9...	38.64	38.64	H1-1b
609	M705	HSS6x6x4	.086	61...	2	.007	61...	y 5	207.1...	216.9...	38.64	38.64	H1-1b
610	M708	HSS6x6x4	.096	64...	2	.043	0	z 2	205.9...	216.9...	38.64	38.64	H1-1

Envelope AISC 14th(360-10): LRFD Steel Code Checks (Continued)

Member	Shape	Code Check	Lo...	LC	Shear ...	Lo...	phi*P...	phi*P...	phi*Mn...	phi*Mn...	Eqn.		
633	M733	HSS4x4x3	.107	40	5	.028	40	y 5	102.1...	106.8...	12.662	12.662	... H1-1b
634	M734	HSS4x4x3	.106	0	5	.025	40	y 5	102.1...	106.8...	12.662	12.662	... H1-1b
635	M735	HSS4x4x3	.100	40	2	.022	40	y 5	102.1...	106.8...	12.662	12.662	... H1-1b
636	M736	HSS4x4x3	.079	40	5	.024	40	y 5	102.1...	106.8...	12.662	12.662	... H1-1b
637	M737	HSS4x4x3	.016	40	2	.004	0	y 2	102.1...	106.8...	12.662	12.662	... H1-1b
638	M738	HSS4x4x3	.079	40	5	.024	40	y 5	102.1...	106.8...	12.662	12.662	... H1-1b
639	M739	HSS4x4x3	.100	40	2	.022	40	y 5	102.1...	106.8...	12.662	12.662	... H1-1b
640	M740	HSS4x4x3	.106	0	5	.025	40	y 5	102.1...	106.8...	12.662	12.662	... H1-1b
641	M741	HSS4x4x3	.107	40	5	.028	40	y 5	102.1...	106.8...	12.662	12.662	... H1-1b
642	M742	HSS4x4x3	.115	40	5	.029	40	y 5	102.1...	106.8...	12.662	12.662	... H1-1b
643	M743	HSS4x4x3	.173	40	5	.034	40	y 5	102.1...	106.8...	12.662	12.662	... H1-1b
644	M744	HSS4x4x3	.151	0	5	.038	40	y 5	102.1...	106.8...	12.662	12.662	... H1-1b
645	M745	HSS4x4x3	.149	40	5	.035	0	z 5	102.1...	106.8...	12.662	12.662	... H1-1b
646	M746	HSS4x4x3	.109	0	5	.039	0	z 5	102.1...	106.8...	12.662	12.662	... H1-1b
647	M748	HSS4x4x3	.136	0	5	.009	0	y 5	91.99	106.8...	12.662	12.662	... H1-1b
648	M749	HSS4x4x3	.176	0	5	.012	0	y 2	91.99	106.8...	12.662	12.662	... H1-1b
649	M750	HSS4x4x3	.129	0	5	.018	0	y 5	91.99	106.8...	12.662	12.662	... H1-1b
650	M751	HSS4x4x3	.124	0	2	.015	0	y 2	91.99	106.8...	12.662	12.662	... H1-1b
651	M752	HSS4x4x3	.096	0	5	.018	0	y 5	91.99	106.8...	12.662	12.662	... H1-1b
652	M753	HSS4x4x3	.085	0	2	.013	0	y 2	91.99	106.8...	12.662	12.662	... H1-1b
653	M754	HSS4x4x3	.073	0	5	.015	0	y 5	91.99	106.8...	12.662	12.662	... H1-1b
654	M755	HSS4x4x3	.060	0	5	.009	0	y 2	91.99	106.8...	12.662	12.662	... H1-1b
655	M756	HSS4x4x3	.035	73...	5	.006	0	y 5	91.99	106.8...	12.662	12.662	... H1-1b
656	M757	HSS4x4x3	.035	0	5	.006	73...	y 5	91.99	106.8...	12.662	12.662	... H1-1b
657	M758	HSS4x4x3	.060	73...	5	.009	0	y 2	91.99	106.8...	12.662	12.662	... H1-1b
658	M759	HSS4x4x3	.073	73...	5	.015	73...	y 5	91.99	106.8...	12.662	12.662	... H1-1b
659	M760	HSS4x4x3	.085	73...	2	.013	0	y 2	91.99	106.8...	12.662	12.662	... H1-1b
660	M761	HSS4x4x3	.096	73...	5	.018	73...	y 5	91.99	106.8...	12.662	12.662	... H1-1b
661	M762	HSS4x4x3	.124	73...	2	.015	0	y 2	91.99	106.8...	12.662	12.662	... H1-1b
662	M763	HSS4x4x3	.129	73...	5	.018	73...	y 5	91.99	106.8...	12.662	12.662	... H1-1b
663	M764	HSS4x4x3	.176	0	5	.012	0	y 2	91.99	106.8...	12.662	12.662	... H1-1b
664	M765	HSS4x4x3	.136	73...	5	.009	73...	y 5	91.99	106.8...	12.662	12.662	... H1-1b
665	M768	HSS4x4x3	.102	77...	2	.012	0	y 2	90.334	106.8...	12.662	12.662	... H1-1b
666	M769	HSS4x4x3	.105	0	5	.012	0	y 5	90.698	106.8...	12.662	12.662	... H1-1b
667	M770	HSS4x4x3	.056	0	5	.008	75...	y 5	91.018	106.8...	12.662	12.662	... H1-1b
668	M771	HSS4x4x3	.063	0	2	.007	0	z 2	91.293	106.8...	12.662	12.662	... H1-1b
669	M772	HSS4x4x3	.066	0	5	.010	0	y 5	91.523	106.8...	12.662	12.662	... H1-1b
670	M773	HSS4x4x3	.069	0	2	.008	0	y 2	91.707	106.8...	12.662	12.662	... H1-1b
671	M774	HSS4x4x3	.073	0	5	.010	0	y 5	91.846	106.8...	12.662	12.662	... H1-1b
672	M775	HSS4x4x3	.059	0	2	.005	73...	y 5	91.938	106.8...	12.662	12.662	... H1-1b
673	M776	HSS4x4x3	.037	0	5	.004	73...	y 4	91.984	106.8...	12.662	12.662	... H1-1b
674	M777	HSS4x4x3	.037	73...	5	.004	0	y 4	91.984	106.8...	12.662	12.662	... H1-1b
675	M778	HSS4x4x3	.059	73...	2	.005	0	y 5	91.938	106.8...	12.662	12.662	... H1-1b
676	M779	HSS4x4x3	.073	73...	5	.010	73...	y 5	91.846	106.8...	12.662	12.662	... H1-1b
677	M780	HSS4x4x3	.069	73...	2	.008	0	y 2	91.707	106.8...	12.662	12.662	... H1-1b
678	M781	HSS4x4x3	.066	74...	5	.010	74...	y 5	91.523	106.8...	12.662	12.662	... H1-1b
679	M782	HSS4x4x3	.063	74...	2	.007	0	z 2	91.293	106.8...	12.662	12.662	... H1-1b
680	M783	HSS4x4x3	.056	75...	5	.008	0	y 5	91.018	106.8...	12.662	12.662	... H1-1b
681	M784	HSS4x4x3	.105	76...	5	.012	76...	y 5	90.698	106.8...	12.662	12.662	... H1-1b
682	M785	HSS4x4x3	.102	0	2	.012	0	y 2	90.334	106.8...	12.662	12.662	... H1-1b
683	M787	HSS4x4x3	.379	0	5	.074	0	z 2	102.1...	106.8...	12.662	12.662	... H1-1b
684	M788	HSS4x4x3	.353	0	5	.077	0	z 5	102.1...	106.8...	12.662	12.662	... H1-1b
685	M789	HSS4x4x3	.271	0	5	.072	0	z 5	102.1...	106.8...	12.662	12.662	... H1-1b
686	M790	HSS4x4x3	.273	40	5	.075	0	z 5	102.1...	106.8...	12.662	12.662	... H1-1b
687	M791	HSS4x4x3	.264	40	5	.066	0	z 5	102.1...	106.8...	12.662	12.662	... H1-1b
688	M792	HSS4x4x3	.265	40	5	.060	0	z 5	102.1...	106.8...	12.662	12.662	... H1-1b
689	M793	HSS4x4x3	.249	40	5	.050	0	z 5	102.1...	106.8...	12.662	12.662	... H1-1b
690	M794	HSS4x4x3	.208	0	2	.037	0	z 5	102.1...	106.8...	12.662	12.662	... H1-1b
691	M795	HSS4x4x3	.134	40	5	.020	0	z 2	102.1...	106.8...	12.662	12.662	... H1-1b

Envelope AISC 14th(360-10): LRFD Steel Code Checks (Continued)

Member	Shape	Code Check	Lo...	LC	Shear ...	Lo...	phi*P...	phi*P...	phi*Mn...	phi*Mn...	Eqn.		
692	M796	HSS4x4x3	.010	0	5	.003	0	y 5	102.1...	106.8...	12.662	12.662	... H1-1b
693	M797	HSS4x4x3	.134	40	5	.020	0	z 2	102.1...	106.8...	12.662	12.662	... H1-1b
694	M798	HSS4x4x3	.208	0	2	.037	0	z 5	102.1...	106.8...	12.662	12.662	... H1-1b
695	M799	HSS4x4x3	.249	40	5	.050	0	z 5	102.1...	106.8...	12.662	12.662	... H1-1b
696	M800	HSS4x4x3	.265	40	5	.060	0	z 5	102.1...	106.8...	12.662	12.662	... H1-1b
697	M801	HSS4x4x3	.264	40	5	.066	0	z 5	102.1...	106.8...	12.662	12.662	... H1-1b
698	M802	HSS4x4x3	.273	40	5	.075	0	z 5	102.1...	106.8...	12.662	12.662	... H1-1b
699	M803	HSS4x4x3	.271	0	5	.072	0	z 5	102.1...	106.8...	12.662	12.662	... H1-1b
700	M804	HSS4x4x3	.353	0	5	.077	0	z 5	102.1...	106.8...	12.662	12.662	... H1-1b
701	M805	HSS4x4x3	.379	0	5	.074	0	z 2	102.1...	106.8...	12.662	12.662	... H1-1b
702	M806	HSS6x6x4	.075	0	5	.026	0	z 5	210.9...	216.9...	38.64	38.64	... H1-1b
703	M807	HSS6x6x4	.061	0	2	.025	0	y 2	167.0...	216.9...	38.64	38.64	... H1-1b
704	M808	HSS6x6x4	.080	0	5	.020	0	y 5	210.9...	216.9...	38.64	38.64	... H1-1b
705	M809	HSS6x6x4	.098	0	5	.030	0	y 5	167.0...	216.9...	38.64	38.64	... H1-1b
706	M810	HSS6x6x4	.065	0	5	.024	0	z 2	211.8...	216.9...	38.64	38.64	... H1-1b
707	M811	HSS6x6x4	.109	0	2	.035	0	y 2	179.53	216.9...	38.64	38.64	... H1-1b
708	M812	HSS6x6x4	.060	0	2	.026	0	z 2	211.8...	216.9...	38.64	38.64	... H1-1b
709	M813	HSS6x6x4	.169	0	5	.040	0	y 5	179.53	216.9...	38.64	38.64	... H1-1b
710	M814	HSS6x6x4	.071	0	5	.023	0	y 5	212.5...	216.9...	38.64	38.64	... H1-1b
711	M815	HSS6x6x4	.142	0	2	.044	0	y 2	189.5...	216.9...	38.64	38.64	... H1-1b
712	M816	HSS6x6x4	.064	40...	5	.020	0	z 5	212.5...	216.9...	38.64	38.64	... H1-1b
713	M817	HSS6x6x4	.211	0	5	.055	0	y 5	189.5...	216.9...	38.64	38.64	... H1-1b
714	M818	HSS6x6x4	.060	37...	2	.033	0	y 5	213.1...	216.9...	38.64	38.64	... H1-1b
715	M819	HSS6x6x4	.148	0	2	.054	0	y 2	197.1...	216.9...	38.64	38.64	... H1-1b
716	M820	HSS6x6x4	.081	37...	5	.035	0	y 2	213.1...	216.9...	38.64	38.64	... H1-1b
717	M821	HSS6x6x4	.234	0	5	.069	0	y 5	197.1...	216.9...	38.64	38.64	... H1-1b
718	M822	HSS6x6x4	.067	35.5	2	.035	0	y 2	213.5...	216.9...	38.64	38.64	... H1-1b
719	M823	HSS6x6x4	.161	0	2	.059	0	y 2	202.7...	216.9...	38.64	38.64	... H1-1b
720	M824	HSS6x6x4	.081	35.5	5	.034	0	y 5	213.5...	216.9...	38.64	38.64	... H1-1b
721	M825	HSS6x6x4	.248	0	5	.079	0	y 5	202.7...	216.9...	38.64	38.64	... H1-1b
722	M826	HSS6x6x4	.069	33...	2	.036	0	y 2	213.9...	216.9...	38.64	38.64	... H1-1b
723	M827	HSS6x6x4	.164	0	2	.064	0	y 2	206.7...	216.9...	38.64	38.64	... H1-1b
724	M828	HSS6x6x4	.094	33...	5	.042	0	y 5	213.9...	216.9...	38.64	38.64	... H1-1b
725	M829	HSS6x6x4	.262	0	5	.088	0	y 5	206.7...	216.9...	38.64	38.64	... H1-1b
726	M830	HSS6x6x4	.078	31...	2	.039	0	y 2	214.2...	216.9...	38.64	38.64	... H1-1b
727	M831	HSS6x6x4	.16										

Envelope AISC 14th(360-10): LRFD Steel Code Checks (Continued)

Member	Shape	Code Check	Lo...	LC	Shear ...	Lo...	phi*P...	phi*P...	phi*Mn...	phi*Mn...	Eqn.		
751	M855	HSS6x6x4	.164	0	2	.064	0	y 2	209.4	216.9	38.64	38.64	H1-1b
752	M856	HSS6x6x4	.097	31	5	.040	0	y 5	214.2	216.9	38.64	38.64	H1-1b
753	M857	HSS6x6x4	.247	0	5	.089	0	y 5	209.4	216.9	38.64	38.64	H1-1b
754	M858	HSS6x6x4	.069	33	2	.036	0	y 2	213.9	216.9	38.64	38.64	H1-1b
755	M859	HSS6x6x4	.164	0	2	.064	0	y 2	206.7	216.9	38.64	38.64	H1-1b
756	M860	HSS6x6x4	.094	33	5	.042	0	y 5	213.9	216.9	38.64	38.64	H1-1b
757	M861	HSS6x6x4	.262	0	5	.088	0	y 5	206.7	216.9	38.64	38.64	H1-1b
758	M862	HSS6x6x4	.067	35.5	2	.035	0	y 2	213.5	216.9	38.64	38.64	H1-1b
759	M863	HSS6x6x4	.161	0	2	.059	0	y 2	202.7	216.9	38.64	38.64	H1-1b
760	M864	HSS6x6x4	.081	35.5	5	.034	0	y 5	213.5	216.9	38.64	38.64	H1-1b
761	M865	HSS6x6x4	.248	0	5	.079	0	y 5	202.7	216.9	38.64	38.64	H1-1b
762	M866	HSS6x6x4	.060	37	2	.033	0	y 5	213.1	216.9	38.64	38.64	H1-1b
763	M867	HSS6x6x4	.148	0	2	.054	0	y 2	197.1	216.9	38.64	38.64	H1-1b
764	M868	HSS6x6x4	.081	37	5	.035	0	y 2	213.1	216.9	38.64	38.64	H1-1b
765	M869	HSS6x6x4	.234	0	5	.069	0	y 5	197.1	216.9	38.64	38.64	H1-1b
766	M870	HSS6x6x4	.071	0	5	.023	0	y 5	212.5	216.9	38.64	38.64	H1-1b
767	M871	HSS6x6x4	.142	0	2	.044	0	y 2	189.5	216.9	38.64	38.64	H1-1b
768	M872	HSS6x6x4	.064	40	5	.020	0	z 5	212.5	216.9	38.64	38.64	H1-1b
769	M873	HSS6x6x4	.211	0	5	.055	0	y 5	189.5	216.9	38.64	38.64	H1-1b
770	M874	HSS6x6x4	.065	0	5	.024	0	z 2	211.8	216.9	38.64	38.64	H1-1b
771	M875	HSS6x6x4	.109	0	2	.035	0	y 2	179.53	216.9	38.64	38.64	H1-1b
772	M876	HSS6x6x4	.060	0	2	.026	0	z 2	211.8	216.9	38.64	38.64	H1-1b
773	M877	HSS6x6x4	.169	0	5	.040	0	y 5	179.53	216.9	38.64	38.64	H1-1b
774	M878	HSS6x6x4	.075	0	5	.026	0	z 5	210.9	216.9	38.64	38.64	H1-1b
775	M879	HSS6x6x4	.061	0	2	.025	0	y 2	167.0	216.9	38.64	38.64	H1-1b
776	M880	HSS6x6x4	.080	0	5	.020	0	y 5	210.9	216.9	38.64	38.64	H1-1b
777	M881	HSS6x6x4	.098	0	5	.030	0	y 5	167.0	216.9	38.64	38.64	H1-1b
778	M883	HSS4x4x3	.052	65	5	.013	0	z 5	94.867	106.8	12.662	12.662	H1-1b
779	M884	HSS4x4x3	.043	43	5	.011	0	z 5	94.953	106.8	12.662	12.662	H1-1b
780	M885	HSS4x4x3	.042	64	5	.013	0	z 5	94.987	106.8	12.662	12.662	H1-1b
781	M886	HSS4x4x3	.040	27	2	.012	0	z 2	94.971	106.8	12.662	12.662	H1-1b
782	M887	HSS4x4x3	.045	59	2	.014	0	z 5	94.904	106.8	12.662	12.662	H1-1b
783	M888	HSS4x4x3	.046	65	5	.011	0	z 2	94.783	106.8	12.662	12.662	H1-1b
784	M889	HSS4x4x3	.048	52	2	.009	0	y 5	94.599	106.8	12.662	12.662	H1-1b
785	M890	HSS4x4x3	.048	37	2	.006	0	z 2	94.344	106.8	12.662	12.662	H1-1b
786	M891	HSS4x4x3	.054	0	2	.009	67	z 2	94.005	106.8	12.662	12.662	H1-1b
787	M892	HSS4x4x3	.054	0	2	.009	0	z 2	94.005	106.8	12.662	12.662	H1-1b
788	M893	HSS4x4x3	.048	29	2	.006	66	z 2	94.344	106.8	12.662	12.662	H1-1b
789	M894	HSS4x4x3	.048	13	2	.009	65	y 5	94.599	106.8	12.662	12.662	H1-1b
790	M895	HSS4x4x3	.046	0	5	.011	65	z 2	94.783	106.8	12.662	12.662	H1-1b
791	M896	HSS4x4x3	.045	5.42	2	.014	65	z 5	94.904	106.8	12.662	12.662	H1-1b
792	M897	HSS4x4x3	.040	37	2	.012	64	z 2	94.971	106.8	12.662	12.662	H1-1b
793	M898	HSS4x4x3	.042	0	5	.013	64	z 5	94.987	106.8	12.662	12.662	H1-1b
794	M899	HSS4x4x3	.043	20	5	.011	64	z 5	94.953	106.8	12.662	12.662	H1-1b
795	M900	HSS4x4x3	.052	0	5	.013	65	z 5	94.867	106.8	12.662	12.662	H1-1b
796	M903	HSS4x4x3	.070	65	5	.012	0	z 5	94.867	106.8	12.662	12.662	H1-1b
797	M904	HSS4x4x3	.055	0	5	.010	0	z 2	94.953	106.8	12.662	12.662	H1-1b
798	M905	HSS4x4x3	.048	64	5	.013	0	y 5	94.987	106.8	12.662	12.662	H1-1b
799	M906	HSS4x4x3	.058	0	5	.013	0	y 5	94.971	106.8	12.662	12.662	H1-1b
800	M907	HSS4x4x3	.057	65	5	.014	0	y 5	94.904	106.8	12.662	12.662	H1-1b
801	M908	HSS4x4x3	.058	65	5	.011	0	z 2	94.783	106.8	12.662	12.662	H1-1b
802	M909	HSS4x4x3	.056	0	5	.009	0	y 5	94.599	106.8	12.662	12.662	H1-1b
803	M910	HSS4x4x3	.053	40	5	.006	0	z 2	94.344	106.8	12.662	12.662	H1-1b
804	M911	HSS4x4x3	.053	26	5	.008	67	z 2	94.005	106.8	12.662	12.662	H1-1b
805	M912	HSS4x4x3	.053	40	5	.008	0	z 2	94.005	106.8	12.662	12.662	H1-1b
806	M913	HSS4x4x3	.053	26	5	.006	66	z 2	94.344	106.8	12.662	12.662	H1-1b
807	M914	HSS4x4x3	.056	65	5	.009	65	y 5	94.599	106.8	12.662	12.662	H1-1b
808	M915	HSS4x4x3	.058	0	5	.011	65	z 2	94.783	106.8	12.662	12.662	H1-1b
809	M916	HSS4x4x3	.057	0	5	.014	65	y 5	94.904	106.8	12.662	12.662	H1-1b

Envelope AISC 14th(360-10): LRFD Steel Code Checks (Continued)

Member	Shape	Code Check	Lo...	LC	Shear ...	Lo...	phi*P...	phi*P...	phi*Mn...	phi*Mn...	Eqn.		
810	M917	HSS4x4x3	.058	64	5	.013	64	y 5	94.971	106.8	12.662	12.662	H1-1b
811	M918	HSS4x4x3	.048	0	5	.013	64	y 5	94.987	106.8	12.662	12.662	H1-1b
812	M919	HSS4x4x3	.055	64	5	.010	64	z 2	94.953	106.8	12.662	12.662	H1-1b
813	M920	HSS4x4x3	.070	0	5	.012	65	z 5	94.867	106.8	12.662	12.662	H1-1b
814	M930	HSS2x2x3	.387	0	2	.038	0	z 6	46.437	49.266	2.75	2.75	H1-1b
815	M931	HSS2x2x3	.175	0	5	.014	0	z 2	30.861	49.266	2.75	2.75	H1-1b
816	M932	HSS2x2x3	.245	61.2	5	.016	0	z 5	30.861	49.266	2.75	2.75	H1-1a
817	M933	HSS2x2x3	.336	61.2	5	.017	0	z 5	30.861	49.266	2.75	2.75	H1-1a
818	M934	HSS2x2x3	.252	0	2	.079	0	z 5	44.238	49.266	2.75	2.75	H1-1b
819	M935	HSS2x2x3	.086	0	5	.016	0	z 2	29.089	49.266	2.75	2.75	H1-1b
820	M936	HSS2x2x3	.132	0	5	.014	0	z 5	29.473	49.266	2.75	2.75	H1-1b
821	M937	HSS2x2x3	.131	0	5	.011	0	z 2	29.812	49.266	2.75	2.75	H1-1b
822	M938	HSS2x2x3	.631	0	5	.129	0	z 5	47.049	49.266	2.75	2.75	H1-1b
823	M939	HSS2x2x3	.549	0	5	.129	0	z 5	47.592	49.266	2.75	2.75	H1-1b
824	M940	HSS2x2x3	.169	0	5	.038	0	z 2	47.049	49.266	2.75	2.75	H1-1b
825	M941	HSS2x2x3	.223	16	2	.056	0	z 5	47.592	49.266	2.75	2.75	H1-1b
826	M942	HSS2x2x3	.277	0	2	.048	0	y 2	44.238	49.266	2.75	2.75	H1-1b
827	M943	HSS2x2x3	.354	29	2	.042	0	z 6	44.238	49.266	2.75	2.75	H1-1b
828	M944	HSS2x2x3	.103	61.2	5	.077	61.2	z 5	30.861	49.266	2.75	2.75	H1-1b
829	M945	HSS2x2x3	.225	16	2	.056	0	z 5	47.592	49.266	2.75	2.75	H1-1b
830	M946	HSS2x2x3	.079	61.2	2	.029	61.2	z 2	30.861	49.266	2.75	2.75	H1-1b
831	M947	HSS2x2x3	.086	61.2	5	.092	61.2	z 5	30.861	49.266	2.75	2.75	H1-1b
832	M948	HSS2x2x3	.379	29	2	.054	0	z 5	44.238	49.266	2.75	2.75	H1-1b
833	M949	HSS2x2x3	.083	28	5	.051	53	z 5	30.861	49.266	2.75	2.75	H1-1b
834	M950	HSS2x2x3	.127	61.2	2	.028	53	z 5	30.861	49.266	2.75	2.75	H1-1b
835	M951	HSS2x2x3	.088	61.2	2	.066	0	z 5	30.861	49.266	2.75	2.75	H1-1b
836	M952	HSS2x2x3	.292	0	2	.029	29	z 5	44.238	49.266	2.75	2.75	H1-1b
837	M953	HSS2x2x3	.580	29	2	.080	29	z 2	44.238	49.266	2.75	2.75	H1-1b
838	M954	HSS2x2x3	.410	0	2	.060	29	z 5	44.238	49.266	2.75	2.75	H1-1b
839	M955	HSS2x2x3	.721	29	2	.086	29	z 5	44.238	49.266	2.75	2.75	H1-1b
840	M956	HSS2x2x3	.348	29	2	.057	29	z 5	44.238	49.266	2.75	2.75	H1-1b
841	M957	HSS2x2x3	.560	29	2	.095	29	z 5	44.238	49.266	2.75	2.75	H1-1b
842	M958	HSS2x2x3	.174	29	2	.033	0	y 2	44.238	49.266	2.75	2.75	H1-1b
843	M959	HSS2x2x3	.200	29	5	.088	29	z 5	44.238	49.266	2.75	2.75	H1-1b
844	M960	HSS2x2x3	.100	0	2	.046	0	z 5	30.861	49.266	2.75	2.75	H1-1b
845	M961	HSS2x2x3	.147	61.2	2	.056	51	z 5	30.861	49.266	2.75	2.75	H1-1b
846	M962	HSS2x2x3	.143	61.2	2	.021	51	z 5					

Envelope AISC 14th(360-10): LRFD Steel Code Checks (Continued)

Member	Shape	Code Check	Lo...	LC	Shear ...	Lo...	phi*P...	phi*P...	phi*Mn...	phi*Mn...	Eqn.			
869	M993	HSS2x2x3	.083	33...	5	.050	53...z	5	30.861	49.266	2.75	2.75	...H1-1b	
870	M994	HSS2x2x3	.124	61.2	5	.026	53...z	2	30.861	49.266	2.75	2.75	...H1-1b	
871	M995	HSS2x2x3	.108	0	5	.064	0	z	5	30.861	49.266	2.75	2.75	...H1-1b
872	M996	HSS2x2x3	.315	0	5	.027	29...z	5	44.238	49.266	2.75	2.75	...H1-1b	
873	M997	HSS2x2x3	.612	29...	5	.077	29...z	5	44.238	49.266	2.75	2.75	...H1-1b	
874	M998	HSS2x2x3	.436	0	5	.056	29...z	5	44.238	49.266	2.75	2.75	...H1-1b	
875	M999	HSS2x2x3	.763	29...	5	.082	29...z	5	44.238	49.266	2.75	2.75	...H1-1b	
876	M1000	HSS2x2x3	.380	0	5	.060	0	y	5	44.238	49.266	2.75	2.75	...H1-1b
877	M1001	HSS2x2x3	.596	29...	5	.093	29...z	5	44.238	49.266	2.75	2.75	...H1-1b	
878	M1002	HSS2x2x3	.183	29...	5	.035	0	y	5	44.238	49.266	2.75	2.75	...H1-1b
879	M1003	HSS2x2x3	.227	29...	5	.086	29...z	2	44.238	49.266	2.75	2.75	...H1-1b	
880	M1004	HSS2x2x3	.166	0	5	.045	0	y	5	30.861	49.266	2.75	2.75	...H1-1b
881	M1005	HSS2x2x3	.163	61.2	5	.054	51	z	5	30.861	49.266	2.75	2.75	...H1-1b
882	M1006	HSS2x2x3	.183	0	5	.022	0	y	5	30.861	49.266	2.75	2.75	...H1-1b
883	M1007	HSS2x2x3	.187	0	5	.016	0	y	5	30.861	49.266	2.75	2.75	...H1-1b
884	M1008	HSS2x2x3	.181	0	5	.054	51	z	5	30.861	49.266	2.75	2.75	...H1-1b
885	M1009	HSS2x2x3	.180	0	5	.068	0	z	5	30.861	49.266	2.75	2.75	...H1-1b
886	M1018	HSS2x2x3	.387	0	2	.038	0	z	6	46.437	49.266	2.75	2.75	...H1-1b
887	M1019	HSS2x2x3	.174	0	5	.014	0	z	2	30.861	49.266	2.75	2.75	...H1-1a
888	M1020	HSS2x2x3	.245	61.2	5	.016	0	z	5	30.861	49.266	2.75	2.75	...H1-1a
889	M1021	HSS2x2x3	.336	61.2	5	.017	0	z	5	30.861	49.266	2.75	2.75	...H1-1a
890	M1022	HSS2x2x3	.252	0	2	.079	0	z	5	44.238	49.266	2.75	2.75	...H1-1b
891	M1023	HSS2x2x3	.086	0	5	.016	0	z	2	29.089	49.266	2.75	2.75	...H1-1b
892	M1024	HSS2x2x3	.132	0	5	.014	0	z	5	29.473	49.266	2.75	2.75	...H1-1b
893	M1025	HSS2x2x3	.131	0	5	.011	0	z	2	29.812	49.266	2.75	2.75	...H1-1b
894	M1026	HSS2x2x3	.631	0	5	.129	0	z	5	47.049	49.266	2.75	2.75	...H1-1b
895	M1027	HSS2x2x3	.549	0	5	.129	0	z	5	47.592	49.266	2.75	2.75	...H1-1b
896	M1028	HSS2x2x3	.169	0	5	.038	0	z	2	47.049	49.266	2.75	2.75	...H1-1b
897	M1029	HSS2x2x3	.223	16...	2	.056	0	z	5	47.592	49.266	2.75	2.75	...H1-1b
898	M1030	HSS2x2x3	.277	0	2	.048	0	y	2	44.238	49.266	2.75	2.75	...H1-1b
899	M1031	HSS2x2x3	.354	29...	2	.042	0	z	6	44.238	49.266	2.75	2.75	...H1-1b
900	M1032	HSS2x2x3	.103	61.2	5	.077	61.2	z	5	30.861	49.266	2.75	2.75	...H1-1b
901	M1033	HSS2x2x3	.225	16...	2	.056	0	z	5	47.592	49.266	2.75	2.75	...H1-1b
902	M1034	HSS2x2x3	.079	61.2	2	.029	61.2	z	2	30.861	49.266	2.75	2.75	...H1-1b
903	M1035	HSS2x2x3	.086	61.2	5	.092	61.2	z	5	30.861	49.266	2.75	2.75	...H1-1b
904	M1036	HSS2x2x3	.379	29...	2	.054	0	z	5	44.238	49.266	2.75	2.75	...H1-1b
905	M1037	HSS2x2x3	.083	28...	5	.051	54...	z	5	30.861	49.266	2.75	2.75	...H1-1b
906	M1038	HSS2x2x3	.127	61.2	2	.028	54...	z	5	30.861	49.266	2.75	2.75	...H1-1b
907	M1039	HSS2x2x3	.088	61.2	2	.066	0	z	5	30.861	49.266	2.75	2.75	...H1-1b
908	M1040	HSS2x2x3	.292	0	2	.029	29...	z	5	44.238	49.266	2.75	2.75	...H1-1b
909	M1041	HSS2x2x3	.580	29...	2	.080	29...z	2	44.238	49.266	2.75	2.75	...H1-1b	
910	M1042	HSS2x2x3	.410	0	2	.060	29...z	5	44.238	49.266	2.75	2.75	...H1-1b	
911	M1043	HSS2x2x3	.721	29...	2	.086	29...z	5	44.238	49.266	2.75	2.75	...H1-1b	
912	M1044	HSS2x2x3	.348	0	2	.057	29...z	5	44.238	49.266	2.75	2.75	...H1-1b	
913	M1045	HSS2x2x3	.560	29...	2	.095	29...z	5	44.238	49.266	2.75	2.75	...H1-1b	
914	M1046	HSS2x2x3	.174	29...	2	.033	0	y	2	44.238	49.266	2.75	2.75	...H1-1b
915	M1047	HSS2x2x3	.200	29...	5	.088	29...z	5	44.238	49.266	2.75	2.75	...H1-1b	
916	M1048	HSS2x2x3	.100	0	2	.046	0	z	5	30.861	49.266	2.75	2.75	...H1-1b
917	M1049	HSS2x2x3	.147	61.2	2	.056	51	z	5	30.861	49.266	2.75	2.75	...H1-1b
918	M1050	HSS2x2x3	.143	61.2	2	.021	51...	z	5	30.861	49.266	2.75	2.75	...H1-1b
919	M1051	HSS2x2x3	.124	0	2	.015	51	z	2	30.861	49.266	2.75	2.75	...H1-1b
920	M1052	HSS2x2x3	.122	61.2	2	.056	51...	z	5	30.861	49.266	2.75	2.75	...H1-1b
921	M1053	HSS2x2x3	.118	0	2	.070	0	z	5	30.861	49.266	2.75	2.75	...H1-1b
922	M1062	HSS2x2x3	.388	0	5	.036	0	z	2	46.437	49.266	2.75	2.75	...H1-1b
923	M1063	HSS2x2x3	.099	0	5	.014	0	z	5	30.861	49.266	2.75	2.75	...H1-1b
924	M1064	HSS2x2x3	.142	0	5	.016	0	z	5	30.861	49.266	2.75	2.75	...H1-1b
925	M1065	HSS2x2x3	.137	0	5	.017	0	z	2	30.861	49.266	2.75	2.75	...H1-1b
926	M1066	HSS2x2x3	.289	0	5	.076	0	z	2	44.238	49.266	2.75	2.75	...H1-1b
927	M1067	HSS2x2x3	.085	0	5	.016	0	z	2	29.089	49.266	2.75	2.75	...H1-1b

Envelope AISC 14th(360-10): LRFD Steel Code Checks (Continued)

Member	Shape	Code Check	Lo...	LC	Shear ...	Lo...	phi*P...	phi*P...	phi*Mn...	phi*Mn...	Eqn.			
928	M1068	HSS2x2x3	.071	0	5	.014	0	z	5	29.473	49.266	2.75	2.75	...H1-1b
929	M1069	HSS2x2x3	.064	0	5	.011	0	z	2	29.812	49.266	2.75	2.75	...H1-1b
930	M1070	HSS2x2x3	.605	0	5	.124	0	z	5	47.049	49.266	2.75	2.75	...H1-1b
931	M1071	HSS2x2x3	.537	0	5	.124	0	z	5	47.592	49.266	2.75	2.75	...H1-1b
932	M1072	HSS2x2x3	.146	0	5	.037	0	z	5	47.049	49.266	2.75	2.75	...H1-1b
933	M1073	HSS2x2x3	.218	16...	5	.054	0	z	5	47.592	49.266	2.75	2.75	...H1-1b
934	M1074	HSS2x2x3	.311	0	5	.053	0	y	5	44.238	49.266	2.75	2.75	...H1-1b
935	M1075	HSS2x2x3	.372	29...	5	.038	0	z	5	44.238	49.266	2.75	2.75	...H1-1b
936	M1076	HSS2x2x3	.098	61.2	5	.073	61.2	z	5	30.861	49.266	2.75	2.75	...H1-1b
937	M1077	HSS2x2x3	.223	16...	5	.052	0	z	5	47.592	49.266	2.75	2.75	...H1-1b
938	M1078	HSS2x2x3	.088	61.2	5	.029	61.2	z	2	30.861	49.266	2.75	2.75	...H1-1b
939	M1079	HSS2x2x3	.081	61.2	2	.087	61.2	z	5	30.861	49.266	2.75	2.75	...H1-1b
940	M1080	HSS2x2x3	.393	29...	5	.051	0	z	5	44.238	49.266	2.75	2.75	...H1-1b
941	M1081	HSS2x2x3	.083	33...	5	.050	54...	z	5	30.861	49.266	2.75	2.75	...H1-1b
942	M1082	HSS2x2x3	.124	61.2	5	.026	54...	z	2	30.861	49.266	2.75	2.75	...H1-1b
943	M1083	HSS2x2x3	.108	0	5	.064	0	z	5	30.861	49.266	2.75	2.75	...H1-1b
944	M1084	HSS2x2x3	.315	0	5	.027	29...	z	5	44.238	49.266	2.75	2.75	...H1-1b
945	M1085	HSS2x2x3	.612	29...	5	.077	29...	z	5	44.238	49.266	2.75	2.75	...H1-1b
946	M1086	HSS2x2x3	.436	0	5	.056	29...	z	5	44.238	49.266	2.75	2.75	...H1-1b
947	M1087	HSS2x2x3	.763	29...	5	.082	29...	z	5	44.238	49.266	2.75	2.75	...H1-1b
948	M1088	HSS2x2x3	.380	0	5	.060	0	y	5	44.238	49.266	2.75	2.75	...H1-1b
949	M1089	HSS2x2x3	.596	29...	5	.093	29...	z	5	44.238	49.266	2.75	2.75	...H1-1b
950	M1090	HSS2x2x3	.183	29...	5	.035	0	y	5	44.238	49.266	2.75	2.75	...H1-1b
951	M1091	HSS2x2x3	.227	29...	5	.086	29...	z	2	44.238	49.266	2.75	2.75	...H1-1b
952	M1092	HSS2x2x3	.166	0	5	.045	0	y	5	30.861	49.266	2.75	2.75	...H1-1b
953	M1093	HSS2x2x3	.163	61.2	5	.054	51	z	5	30.861	49.266	2.75	2.75	...H1-1b
954	M1094	HSS2x2x3	.183	0	5	.022	0	y	5	30.861	49.266	2.75	2.75	...H1-1b
955	M1095	HSS2x2x3	.187	0	5	.016	0	y	5	30.861	49.266	2.75	2.75	...H1-1b
956	M1096	HSS2x2x3	.181	0	5	.054	51...	z	5	30.861	49.266	2.75	2.75	...H1-1b
957	M1097	HSS2x2x3	.180	0	5	.068	0	z	5	30.861	49.266	2.75	2.75	...H1-1b
958	M1088A	HSS8x8x4	.409	0	5	.141	0	z	5	290.78	293.94	66.288	66.288	...H1-1b
959	M1089A	HSS8x8x4	.133	0	5	.033	0	y	2	290.78	293.94	66.288	66.288	...H1-1b
960	M1090A	HSS12x8x4	.064	40	5	.								

Envelope AISC 14th(360-10): LRFD Steel Code Checks (Continued)

Member	Shape	Code Check	Lo...	LC	Shear ...	Lo...	phi*P...	phi*P...	phi*Mn...	phi*Mn...	Eqn...		
987	M1103	HSS6x6x4	.224	0	4	.027	0	z 2	205.0...	216.9...	38.64	38.64	...H1-1b
988	M1104	HSS4x4x3	.227	78...	5	.025	78...	y 5	89.925	106.8...	12.662	12.662	...H1-1b
989	M1105	HSS4x4x3	.246	73...	5	.012	73...	y 5	91.99	106.8...	12.662	12.662	...H1-1a
990	M1106	HSS4x4x3	.051	0	5	.026	0	z 5	94.724	106.8...	12.662	12.662	...H1-1b
991	M1107	HSS4x4x3	.065	0	4	.025	0	z 2	94.724	106.8...	12.662	12.662	...H1-1b
992	M1108	HSS4x4x3	.051	65...	5	.026	65...	z 5	94.724	106.8...	12.662	12.662	...H1-1b
993	M1109	HSS4x4x3	.065	65...	4	.025	65...	z 2	94.724	106.8...	12.662	12.662	...H1-1b

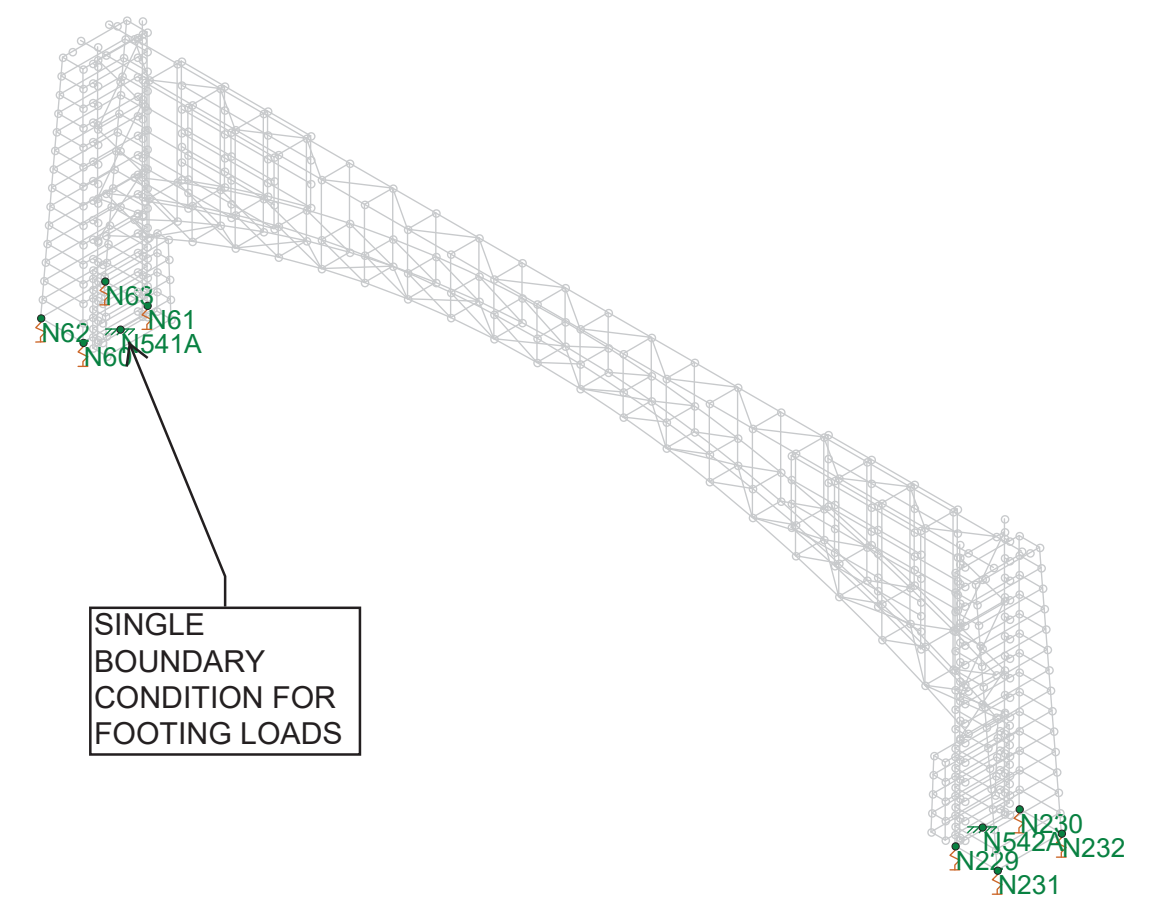
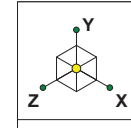

Envelope Only Solution

Basic Load Cases

BLC Description	Category	X Gravity	Y Gravity	Z Gravity	Joint	Point	Distributed Area(Me... Surface(...
1 D	DL		-1				180
2 W	WL						200 104
3 F	None						200 104
4 BLC 1 Transient Ar...	None						690
5 BLC 2 Transient Ar...	None						417
6 BLC 3 Transient Ar...	None						417

Load Combinations

Description	So...	PDelta	S...	BLCFac..	BLCFac..	BLCFac..	BLCFac..	BLCFac..	BLCFac..	BLCFac..	BLCFac..	BLCFac..	BLCFac..
1 D	Yes	Y	1	1									
2 W	Yes	Y	2	1									
3 F	Yes	Y	3	1									
4 1.25D	Yes	Y	1	1.25									
5 1.1D+1.0W	Yes	Y	1	1.1	2	1							
6 0.9D+1.0W	Yes	Y	1	.9	2	1							
7 1.0D+1.0F	Yes	Y	1	1	3	1							

Envelope Joint Reactions

Joint		X [k]	LC	Y [k]	LC	Z [k]	LC	MX [k-ft]	LC	MY [k-ft]	LC	MZ [k-ft]	LC
1 N62	max	0	1	5.006	4	0	1	0	1	0	1	0	1
2	min	0	1	0	2	0	1	0	1	0	1	0	1
3 N63	max	0	1	5.679	5	0	1	0	1	0	1	0	1
4	min	0	1	.176	3	0	1	0	1	0	1	0	1
5 N60	max	0	1	.612	4	0	1	0	1	0	1	0	1
6	min	0	1	0	2	0	1	0	1	0	1	0	1
7 N61	max	0	1	2.493	5	0	1	0	1	0	1	0	1
8	min	0	1	.285	3	0	1	0	1	0	1	0	1
9 N230	max	0	1	2.493	5	0	1	0	1	0	1	0	1
10	min	0	1	.285	3	0	1	0	1	0	1	0	1
11 N232	max	0	1	5.685	5	0	1	0	1	0	1	0	1
12	min	0	1	.176	3	0	1	0	1	0	1	0	1
13 N231	max	0	1	4.997	4	0	1	0	1	0	1	0	1
14	min	0	1	0	2	0	1	0	1	0	1	0	1
15 N229	max	0	1	.612	4	0	1	0	1	0	1	0	1
16	min	0	1	0	2	0	1	0	1	0	1	0	1
17 N541A	max	18.849	4	38.915	4	29.276	2	621.216	2	-.081	1	-.003	3
18	min	.038	3	-3.169	2	0	4	.026	1	-73.076	5	-95.704	4
19 N542A	max	-.038	3	38.914	4	29.277	5	621.214	2	73.081	5	95.705	4
20	min	-18.849	4	-3.169	2	0	1	-.033	4	.085	1	.003	3
21 Totals:	max	0	2	100.282	4	58.553	2						
22	min	0	4	0	3	0	4						



Date: Thursday, October 4, 2018
To: Honorable Mayor and City Council
From: Kathy Markus, Information Services

ACTION ITEM

Request:

Location of Archway

Time Estimate:

5 Minutes

Background:

Mitch, Ruth and Greg met with the County. They are in favor of having the archway moved to the location closer to the building so that it does not destroy any trees. Now we need to have a licensed surveyor provide a legal description with the meets and bounds. After we get this information, Fritz will draft an easement.

EHM Engineers has been recommended as a possible surveyor.

This new location will require us to move the walkway that is between the two rose garden areas. We will need to reinstall the bricks because they are recognition bricks.

Approval Process:

Budget Impact:

Regulatory Impact:

History:

N/A

Analysis:

N/A

Conclusion:

It is recommended that we approve EHM engineers to survey the location for the archway for a price not to exceed _____.

Attachments:

None

